

XC6801 Series

ETR2502-006a

500mA 1 Cell Li-ion and Li-Po Battery Linear Charger IC with Constant-Current/Constant-Voltage

GENERAL DESCRIPTION

The XC6801 series is a constant-current/constant-voltage linear charger IC for single cell Lithium-ion and Lithium polymer batteries. The XC6801 includes a reference voltage source, battery voltage monitor, driver transistor, constant-current/constant-voltage charge circuit, overheat protection circuit and phase compensation circuit. The battery charge termination voltage is internally set to 4.2V ±0.7% and the trickle charge voltage and accuracy is 2.9V ±3%. In trickle charge mode, a safe Lithium-ion and Lithium polymer battery charge is possible because approximately only 1/10 of the full charge current is supplied to the battery. As it is possible to select a highly accurate charge current of either 100mA (MAX.) for L level input to the LIM pin or 500mA (MAX.) for H level, the series is ideal for applications where the charge is from USB. The series' charge status output pin, /CHG pin, is capable of checking the IC's charging state via connection to an external LED.

APPLICATIONS

- USB charge applications
- Charging docks, charging cradles
- MP3 players, portable audio players
- Cellular phones, PDAs
- Bluetooth headsets

FEATURES

- Operating Voltage Range : 4.25V ~ 6.0V
- Charge Current : 100mA (MAX.) @ LIM pin=L
(externally set) 500mA (MAX.) @ LIM pin=H
- Charge Termination Voltage : 4.2V ±0.7%
- Trickle Charge Voltage : 2.9V ±3%
- Supply Current (Stand-by) : 12 μA (TYP.)
- Operating Ambient Temperature : - 40°C~ + 85°C
- Packages : SOT-89-5, SOT-25, USP-6C
- Constant-current/constant-voltage operation with thermal shutdown
- Automatic recharge
- Charge status output pin
- Soft-start function (Inrush limit current)
- Environmentally Friendly : EU RoHS Compliant, Pb Free

TYPICAL APPLICATION CIRCUIT

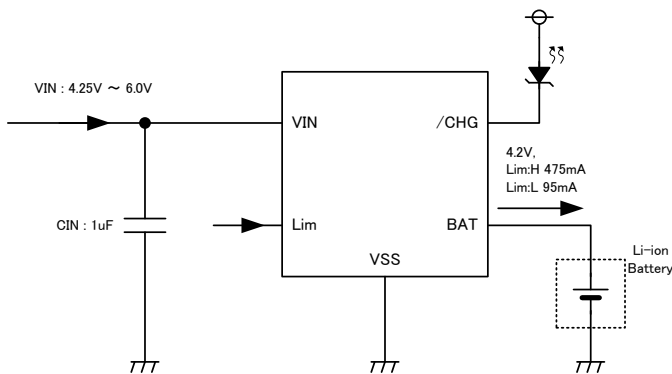

TYPICAL PERFORMANCE CHARACTERISTICS

Battery Charge Cycle

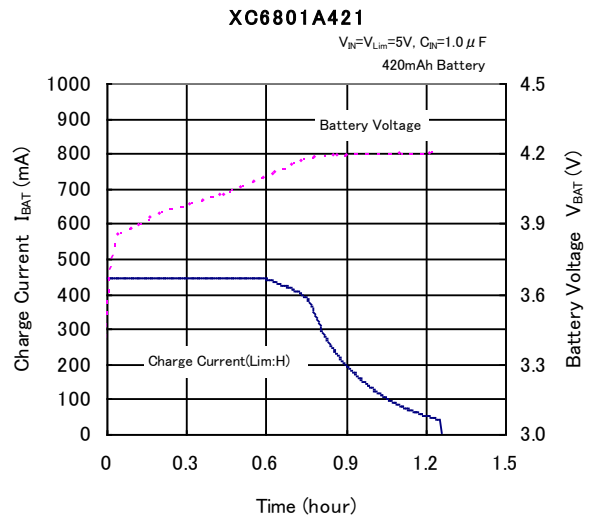

PIN CONFIGURATION

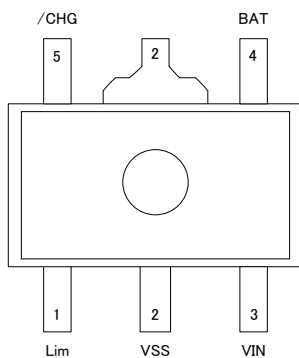

SOT-89-5
(TOP VIEW)

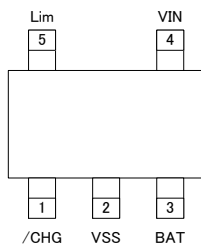

SOT-25
(TOP VIEW)

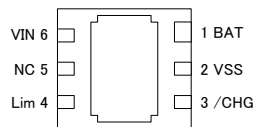

USP-6C
(BOTTOM VIEW)

* The dissipation pad for the USP-6C package should be solder-plated in recommended mount pattern and metal masking so as to enhance mounting strength and heat release. If the pad needs to be connected to other pins, it should be connected to the V_{SS} (No. 2) pin.

PIN ASSIGNMENT

PIN NUMBER			PIN NAME	FUNCTIONS
SOT-25	SOT-89-5	USP-6C		
1	5	3	/CHG	Charge Status Output Pin
2	2	2	V _{SS}	Ground
3	4	1	BAT	Charge Current Pin
4	3	6	V _{IN}	Input Voltage Pin
5	1	4	L _{IM}	Changing Current Switch
-	-	5	NC	No Connection

FUNCTIONS

XC6801A421

PIN NAME	CONDITIONS		IC OPERATION
L _{IM}	L	$0V \leq V_{LIM} \leq 0.4V$	Charging Battery Current 1 (CC Mode)
	H	$1V \leq V_{LIM} \leq 6V$	Charging Battery Current 2 (CC Mode)

*If L_{IM} pin is left open, battery current is unstable. L_{IM} pin level should be fixed "High" or "Low".

PRODUCT CLASSIFICATION

Ordering Information

XC6801A42①②③-④

DESIGNATOR	ITEM	SYMBOL	DESCRIPTION
①	Setting Charge Current	1	L _{IM} "L"=95mA, L _{IM} "H"=475mA
②③-④ ^(*)	Packages (Order Unit)	PR-G	SOT-89-5 (1,000pcs/Reel)
		MR-G	SOT-25 (3,000pcs/Reel)
		ER-G	USP-6C (3,000pcs/Reel)

^(*) The "-G" suffix denotes Halogen and Antimony free as well as being fully EU RoHS compliant.

■ BLOCK DIAGRAM

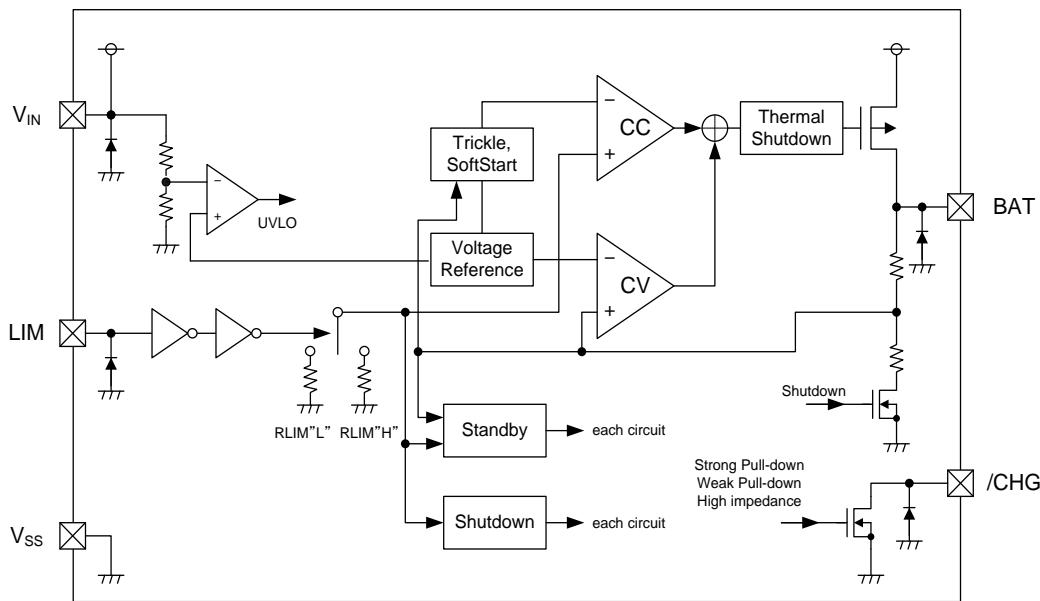

* Diodes inside the circuits are ESD protection diodes and parasitic diodes.

■ ABSOLUTE MAXIMUM RATINGS

Ta=25°C			
PARAMETER	SYMBOL	RATINGS	UNIT
V_{IN} Pin Voltage	V_{IN}	-0.3 ~ +6.5	V
LIM Pin Voltage	V_{LIM}	-0.3 ~ +6.5	V
BAT Pin Voltage	V_{BAT}	-0.3 ~ +6.5	V
/CHG Pin Voltage	$V_{/CHG}$	-0.3 ~ +6.5	V
BAT Pin Current	I_{BAT}	900 ^(*)	mA
Power Dissipation	SOT-25	250	mW
		600 (PCB mounted) ^(*)	
	SOT-89-5	500	
		1300 (PCB mounted) ^(*)	
	USP-6C	120	
		1000 (PCB mounted) ^(*)	
Operating Ambient Temperature	T_{opr}	- 40 ~ + 85	°C
Storage Temperature	T_{stg}	- 55 ~ + 125	°C

All voltages are described based on the V_{SS} pin.

(*1) Please use within the range of $I_{BAT} \leq Pd / (V_{IN} - V_{BAT})$.

(*2) The power dissipation figure shown is PCB mounted.

Please see the power dissipation page for the mounting condition.

ELECTRICAL CHARACTERISTICS

XC6801A421

Ta=25°C

PARAMETER	SYMBOL	CONDITIONS	MIN	TYP	MAX	UNIT	CIRCUIT
Input Voltage	V _{IN}		4.25	-	6.00	V	-
Supply Current	I _{SS}	Charge mode (V _{LIM} =H or V _{LIM} =L)	-	12	30	μA	③
Stand-by Current	I _{STBY}	Stand-by mode	-	12	30	μA	③
Shut-down Current	I _{SHUT}	Shut-down mode (V _{IN} <V _{BAT} or V _{IN} <V _{UVLO})	-	8	18	μA	③
Float Voltage 1	V _{FLOAT1}	Ta=25°C, I _{BAT} =40mA	x0.993	4.2	x1.007	V	②
Float Voltage 2 (*1)	V _{FLOAT2}	0°C ≤ Ta ≤ 50°C, I _{BAT} =40mA	x0.99	4.2	x1.01	V	-
Battery Current 1	I _{BAT1}	V _{BAT} =3.8V, V _{LIM} =L, CC mode	88	95	100	mA	③
Battery Current 2	I _{BAT2}	V _{BAT} =3.8V, V _{LIM} =H, CC mode	440	475	500	mA	③
Battery Current 3	I _{BAT3}	Stand-by mode, V _{BAT} =4.2V	-	-	2.5	μA	③
Battery Current 4	I _{BAT4}	Shut-down mode	-	-	2.0	μA	③
Battery Current 5	I _{BAT5}	Stop mode, V _{IN} =0V	-	-	2.0	μA	③
Trickle Charge Current 1	I _{TRIKL1}	V _{BAT} <V _{TRIKL} (V _{LIM} =L)	7.5	9.5	12.0	mA	③
Trickle Charge Current 2	I _{TRIKL2}	V _{BAT} <V _{TRIKL} (V _{LIM} =H)	37.5	47.5	60.0	mA	③
Trickle Voltage	V _{TRIKL}	V _{LIM} =L, V _{BAT} Rising	2.813	2.9	2.987	V	③
Trickle Voltage Hysteresis Width	V _{TRIKL_HYS}	V _{LIM} =L	58	90	116	mV	③
UVLO Voltage	V _{UVLO}	V _{IN} : L → H	3.686	3.8	3.914	V	⑥
UVLO Hysteresis Width	V _{UVLO_HYS}	-	150	190	280	mV	-
V _{IN} -V _{BAT} Shut-down Voltage	V _{ASD}	V _{IN} : L → H	70	100	140	mV	③
V _{IN} -V _{BAT} Shut-down Voltage Hysteresis Width	V _{ASD_HYS}	-	50	70	90	mV	-
C/10 Charge Termination Current Threshold	I _{TERM}	V _{LIM} =L	0.07	0.1	0.13	mA/mA	②
		V _{LIM} =H	0.07	0.1	0.13	mA/mA	②
/CHG Pin Weak Pull-Down Current	I _{/CHG1}	V _{BAT} =4.3V, V _{/CHG} =5V	8	20	35	μA	③
/CHG Pin Strong Pull-Down Current	I _{/CHG2}	V _{BAT} =4.0V, V _{/CHG} =1V	4	10	18	mA	③
/CHG Pin Output Low Voltage	V _{/CHG}	I _{/CHG} =5mA	-	0.35	0.60	V	④
Recharge Battery Threshold Voltage	ΔV _{RECHRG}	V _{FLOAT1} -V _{RECHRG} (*2)	100	150	200	mV	③
ON Resistance	R _{ON}	-	300	450	800	mΩ	①
Soft-Start Time	t _{SS}	I _{BAT} =0 → I _{BAT2} (V _{LIM} =H)	120	150	180	μs	⑤
Recharge Battery Time	t _{RECHRG}	V _{BAT} : H → L	0.4	1.7	3.2	ms	⑥
Battery Termination Detect Time	t _{TERM}	I _{BAT} falling (Less than I _{TERM})	0.3	1.2	2.4	ms	⑥
L _{LIM} Pin "H" Level Voltage	V _{LIM_H}		1			V	③
L _{LIM} Pin "L" Level Voltage	V _{LIM_L}				0.4	V	③
L _{LIM} Pin "H" Level Current	I _{LIM_H}		-0.1		0.1	μA	①
L _{LIM} Pin "L" Level Current	I _{LIM_L}		-0.1		0.1	μA	①
Thermal Shut-Down Detect Temperature	T _{TSD}	Junction temperature		120		°C	-
Thermal Shut-Down Release Temperature	T _{TSR}	Junction temperature		100		°C	-

Unless otherwise stated, V_{IN}=5.0V.

(*1) The figures under the condition of 0°C ≤ T_a ≤ 50°C are guaranteed by design calculation.

(*2) V_{RECHRG} is a voltage to start recharging while reducing V_{BAT} in stand-by mode from the full charge.

OPERATIONAL DESCRIPTION

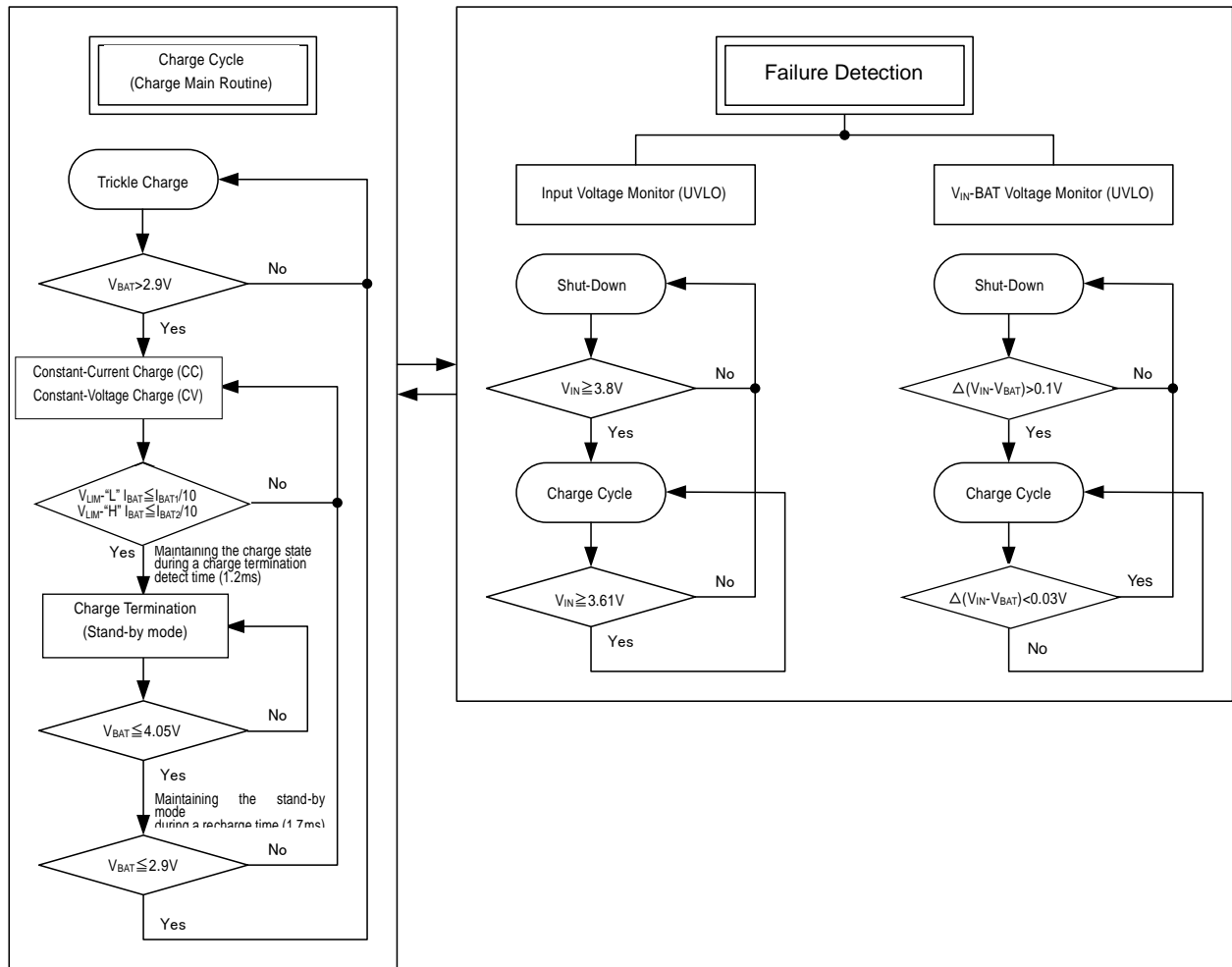

<Charge Cycle>

If the BAT pin trickle voltage is less than 2.9V(TYP.), the charger enters trickle charge mode. In this mode, a safe battery charge is possible because approximately only 1/10 of the charge current is supplied to the battery. When the BAT pin voltage rises above trickle voltage, the charger enters constant-current mode (CC mode) and the battery is charged by the programmed charge current. When the BAT pin voltage reaches 4.2V, the charger enters constant-voltage mode (CV mode) automatically. After this, the charge current starts to drop and when it reaches a level which is 1/10 of the programmed charge current, the charge terminates.

<Setting Charge Current>

The charge current can be set from 475mA(TYP.) or 95mA(TYP.) by the L_{IM} pin.

L_{IM} "H" level input: 475mA(TYP.)

L_{IM} "L" level input: 95mA(TYP.)

<Charge Termination>

The battery charge is terminated when the charge current decreases to 1/10 of the full charging level after the battery pin voltage reaches a float voltage. An internal comparator monitors the I_{SEN} pin voltage to detect the charge termination. When the comparator sees that the I_{SEN} pin voltage is less than 1.2ms (charge termination detect time), the IC enters stand-by mode. A driver transistor turns off during the stand-by mode.

<Automatic Recharge>

In stand-by mode battery voltage falls. When the voltage level at the battery pin drops to recharge battery threshold voltage 4.05V(TYP.) or less, the charge cycle automatically re-start after a delay of 1.7ms. As such, no external activation control is needed.

OPERATIONAL EXPLANATION (Continued)

<Charge Condition Status>

The /CHG pin constantly monitors the charge states classified as below:

- Strong pull-down: $I_{CHG}=10\text{mA}$ (TYP.) in a charge cycle,
- Weak pull-down: $I_{CHG}=20\mu\text{A}$ (TYP.) in a stand-by mode,
- High impedance: in shutdown mode.

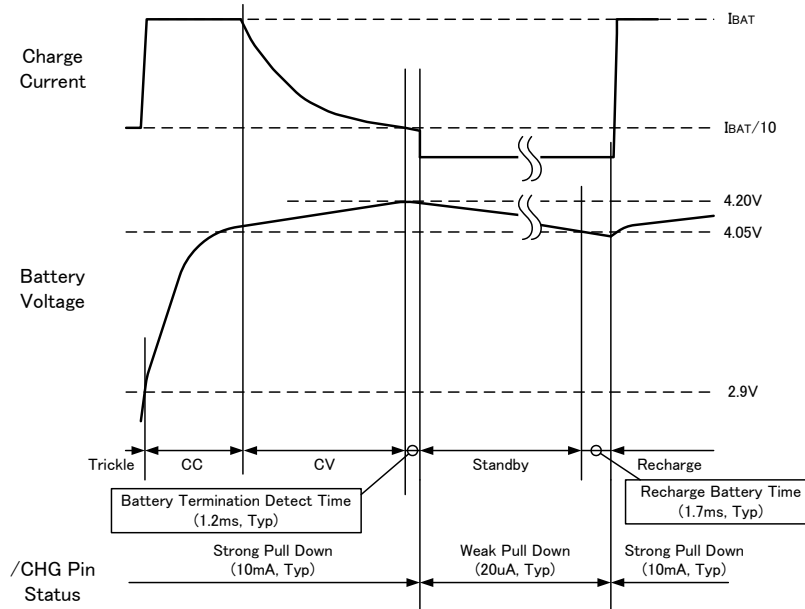

<Connection of Shorted BAT Pin>

Even if the BAT pin is shorted to V_{SS} , a trickle charge mode operates in order to protect the IC from destruction caused by over current.

<Under-voltage Lockout (UVLO)>

The UVLO circuit keeps the charger in shut-down mode until the input voltage, V_{IN} , rises above the UVLO voltage. Moreover, in order to protect the battery charger, the UVLO circuit keeps the charger in shut-down mode when the voltage between the input pin voltage and BAT pin voltage falls to less than 30mV. The charge will not restart until the voltage between the input pin voltage and BAT pin voltage rises more than 100mV. During shut-down mode, the driver transistor turns off but a failure detection circuit operates, and supply current is reduced to $8\mu\text{A}$.

<Soft-Start Function>

To protect against inrush current from the input to the battery, soft-start time is optimized and internally set ($150\mu\text{s}$, TYP.).

<Backflow Prevention Between the BAT Pin and the V_{IN} Pin>

A backflow prevention circuit protects against current flowing from the BAT pin to the V_{IN} pin even if the BAT pin voltage is higher than the V_{IN} pin voltage.

■NOTES ON USE

1. For temporary, transitional voltage drop or voltage rising phenomenon, the IC is liable to malfunction should the ratings be exceeded.
2. Where wiring impedance is high, operations may become unstable due to noise and/or phase lag depending on output current. Please wire the C_{IN} as close to the IC as possible.
3. Torex places an importance on improving our products and their reliability.
We request that users incorporate fail-safe designs and post-aging protection treatment when using Torex products in their systems.

TEST CIRCUITS

CIRCUIT①

ON Resistance, L_{IM} Pin "H" level current,
 L_{IM} Pin "L" level current,

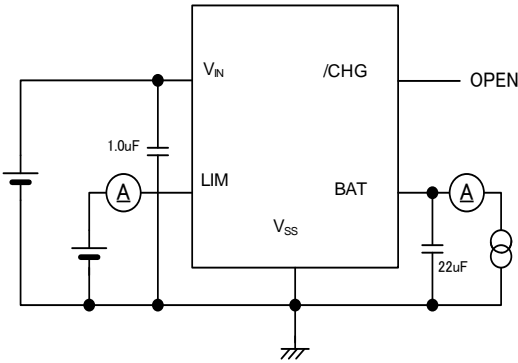

CIRCUIT②

C/10 Charge Termination Current Threshold,
Battery Termination Voltage1

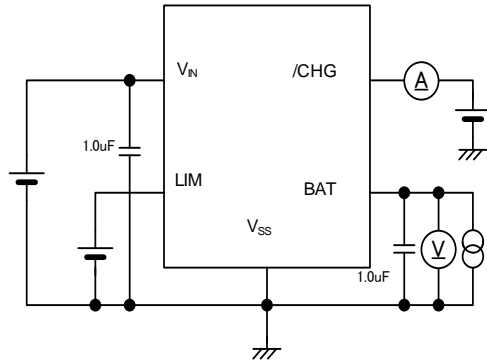

CIRCUIT③

Trickle Charge Current1~2, Battery Current1~5,
 L_{IM} Pin "H" level Voltage, L_{IM} Pin "L" level Voltage,
Trickle Charge Voltage, Recharge Battery Threshold Voltage,
 $V_{IN}-V_{BAT}$ Shut-down Voltage, /CHG Pin Weak_Pull_down Current,
/CHG Pin Strong_Pull_down Current, Supply Current,
Stand-by Current, Shut-down Current

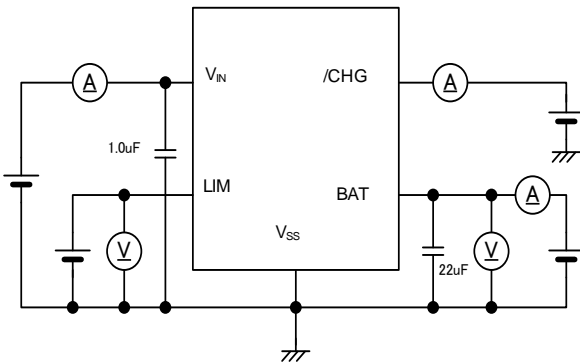

CIRCUIT④

/CHG Pin Output Low Voltage

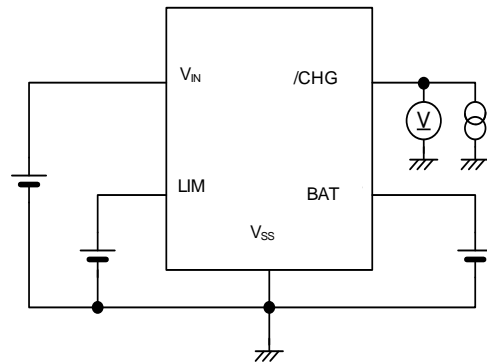

CIRCUIT⑤

Soft-Start Time

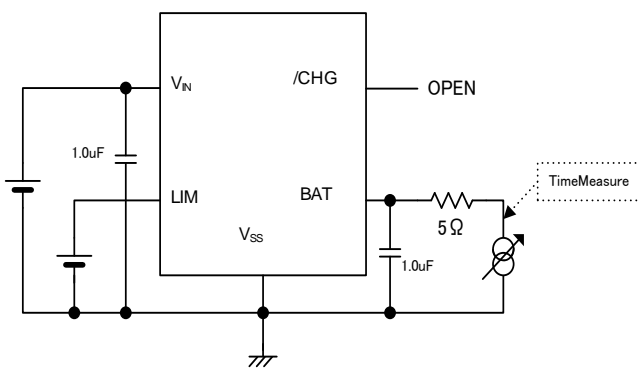

CIRCUIT⑥

Recharge Time at Charge Termination Detect, UVLO Voltage

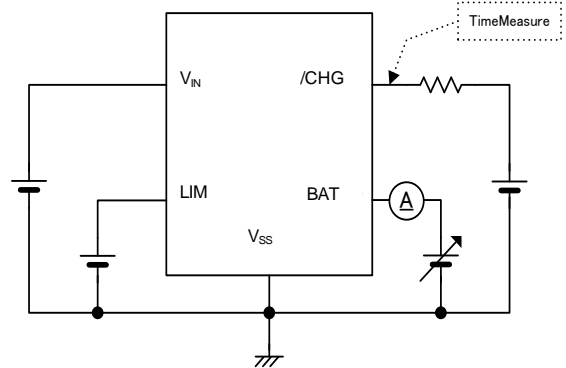

TYPICAL PERFORMANCE CHARACTERISTICS

(1) Charge Cycle

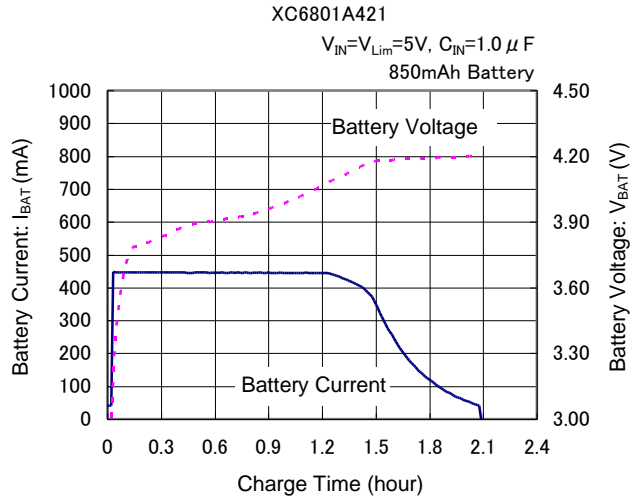
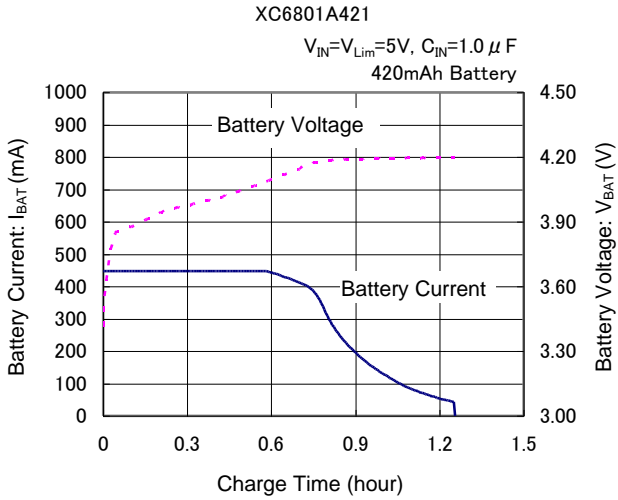

(2) Battery Current vs. Battery Voltage

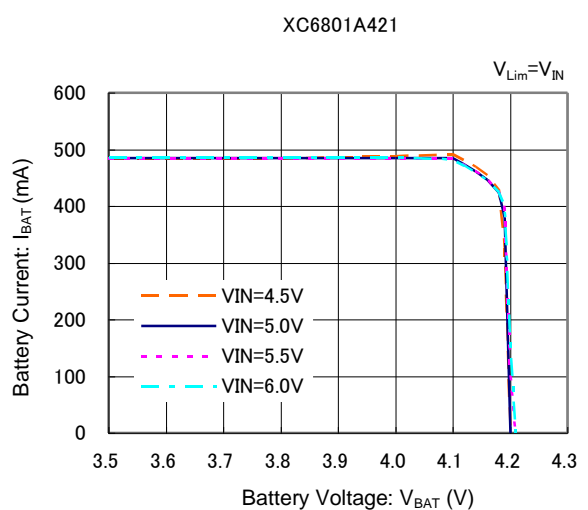
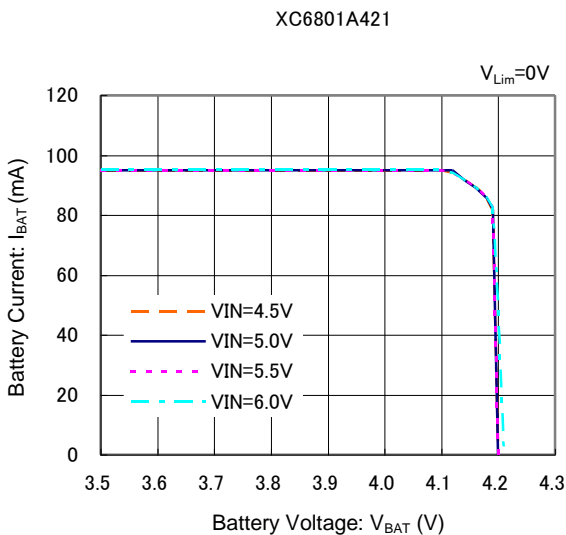
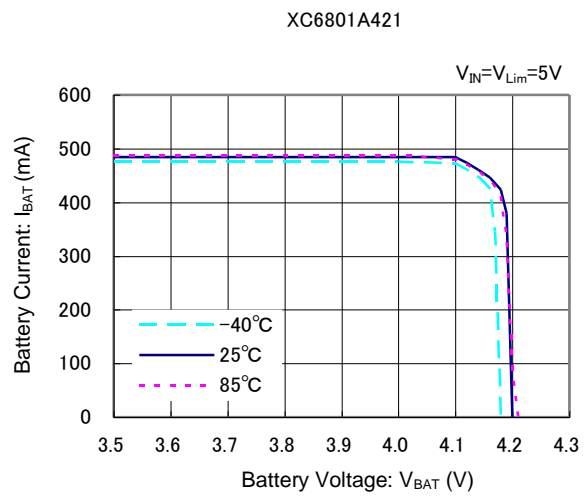
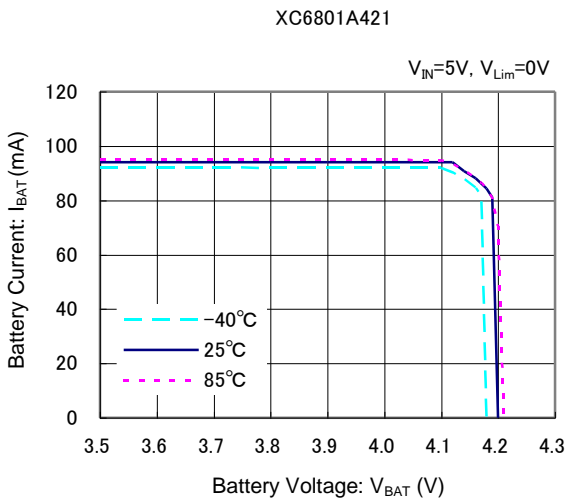

TYPICAL PERFORMANCE CHARACTERISTICS (Continued)

(3) Battery Voltage vs. Battery Current

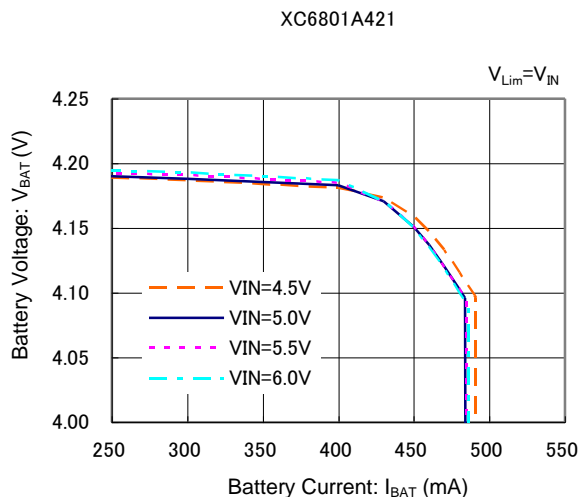
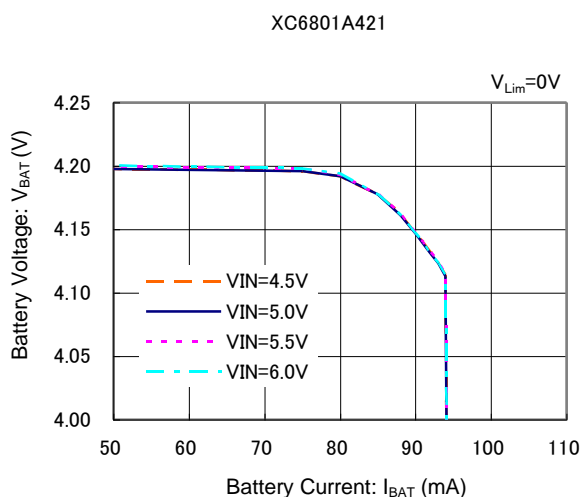
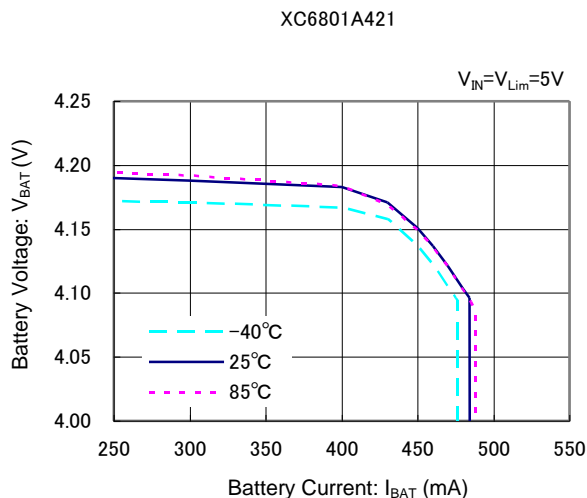
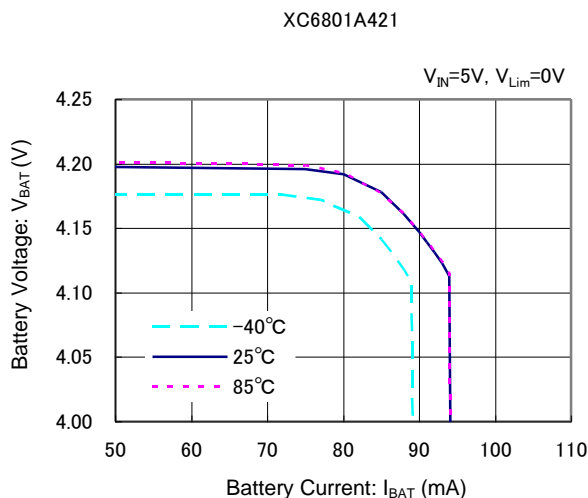

(4) Charge Termination Voltage vs. Ambient Temperature

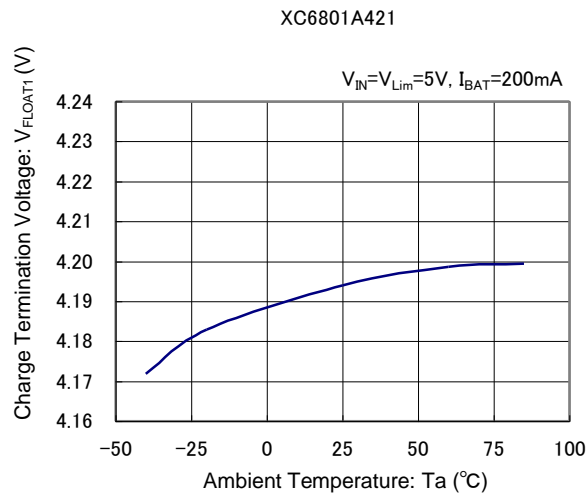
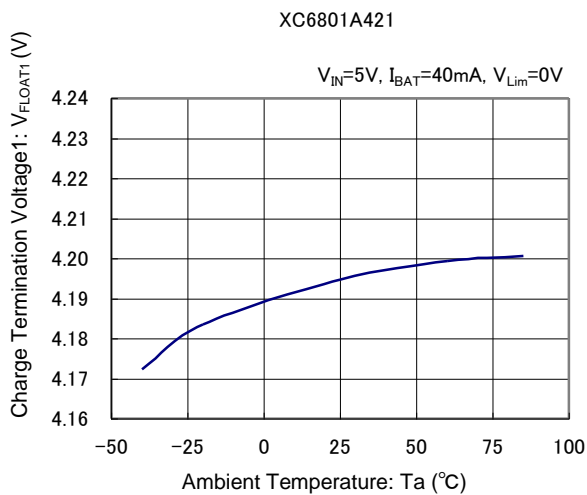

■ TYPICAL PERFORMANCE CHARACTERISTICS (Continued)

(5) Battery Current vs. Ambient Temperature

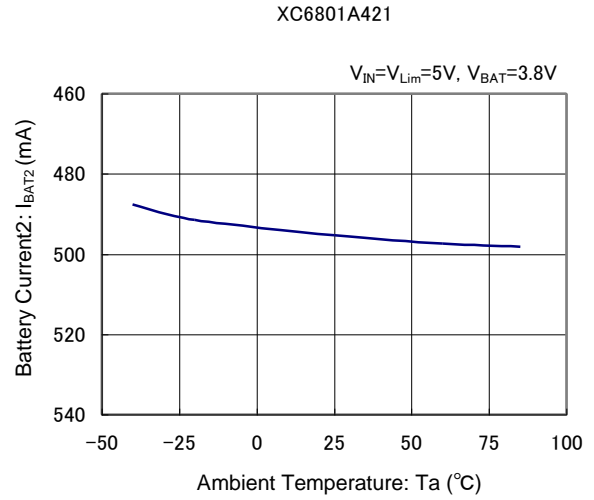
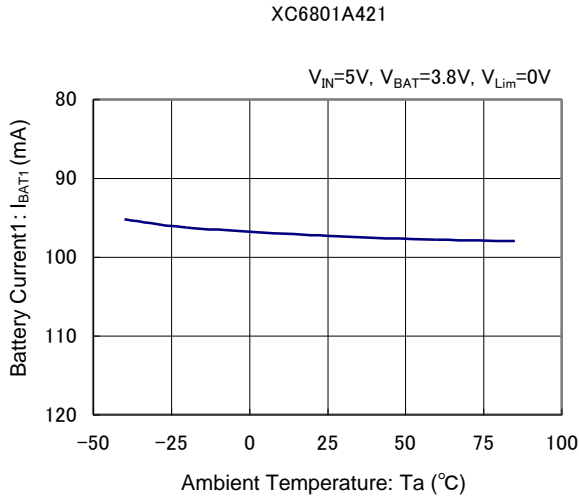

(6) Trickle Charge Current vs. Ambient Temperature

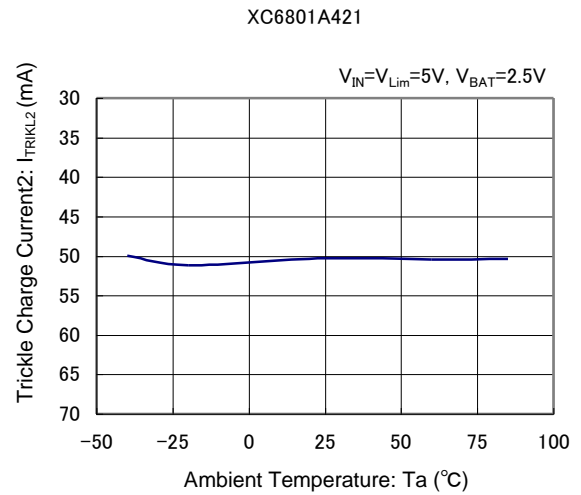
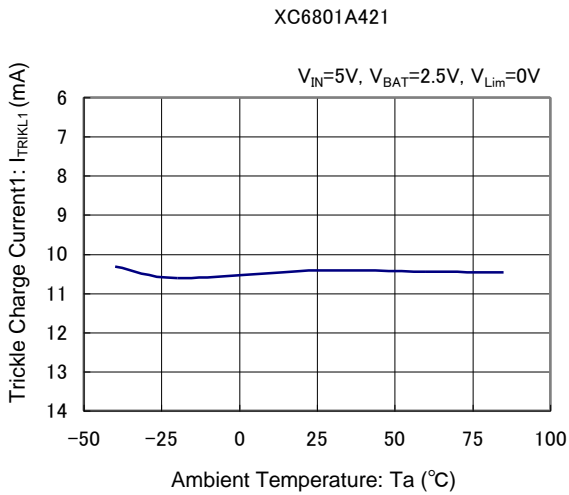

(7) Trickle Voltage vs. Ambient Temperature

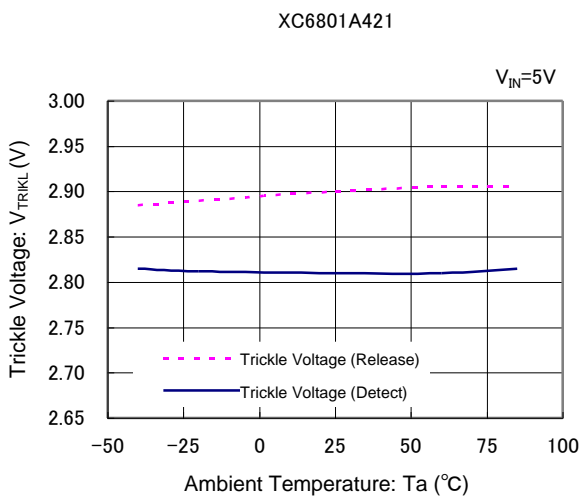

(8) UVLO Voltage vs. Ambient Temperature

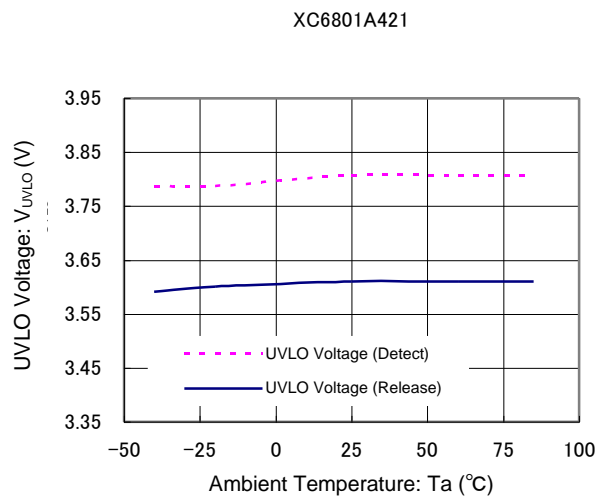

TYPICAL PERFORMANCE CHARACTERISTICS (Continued)

(9) $V_{IN} - V_{BAT}$ Shutdown Voltage vs. Ambient Temperature

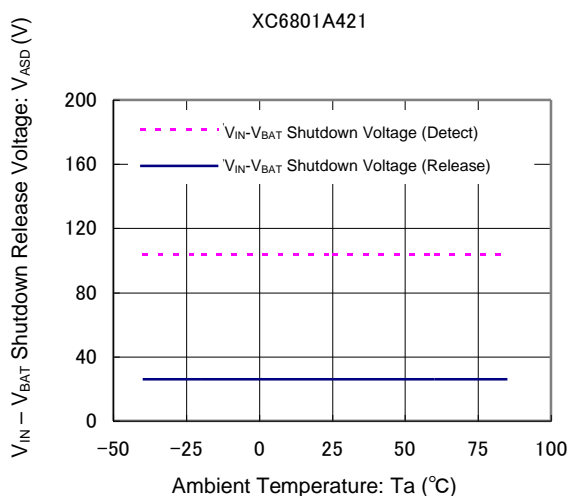

(10) Charge Termination Detect Time vs. Ambient Temperature

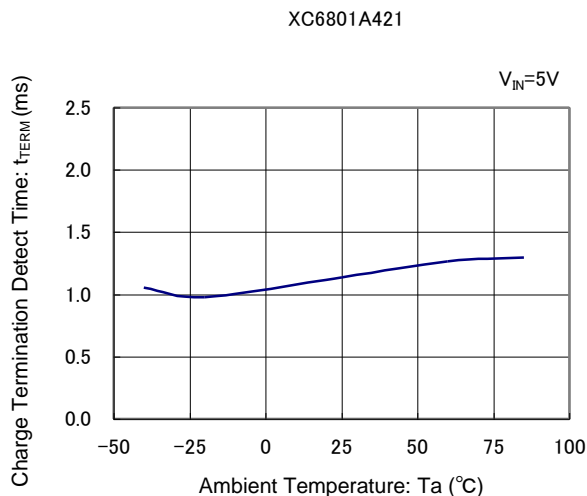

(11) Recharge Time vs. Ambient Temperature

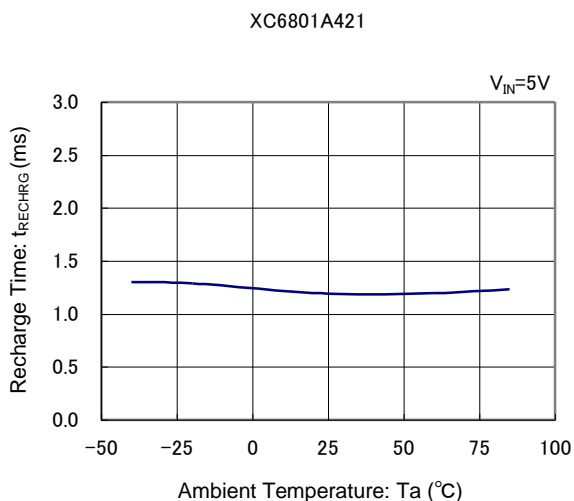

(12) Recharge Threshold Voltage vs. Ambient Temperature

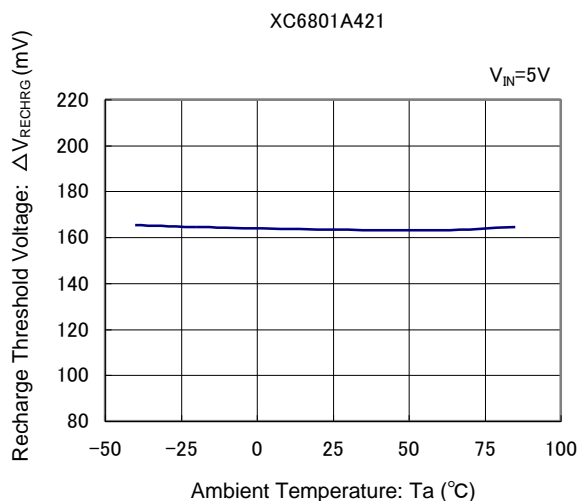

(13) Soft Start Time vs. Ambient Temperature

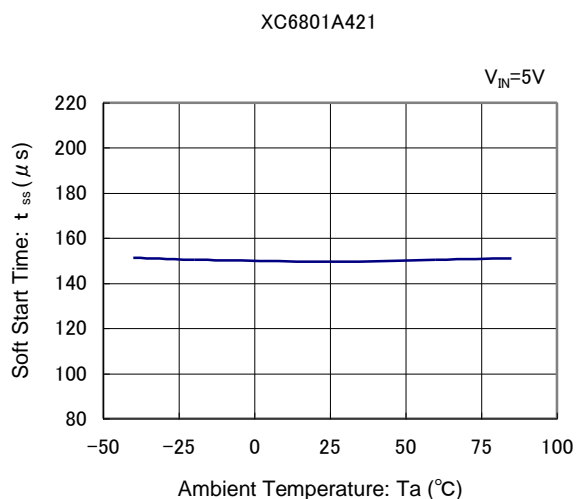

(14) ON Resistance vs. Ambient Temperature

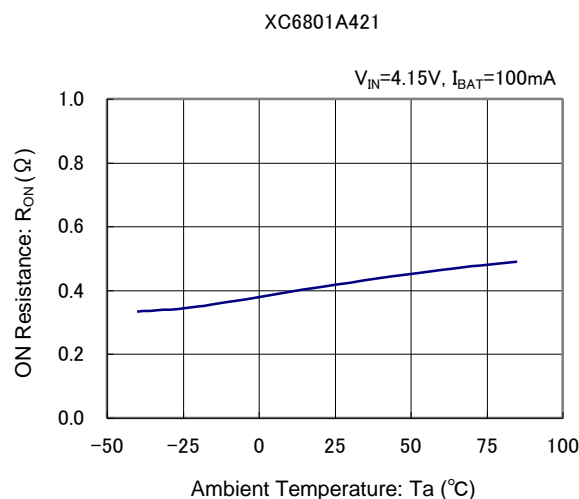

TYPICAL PERFORMANCE CHARACTERISTICS (Continued)

(15) Shutdown Current vs. Ambient Temperature

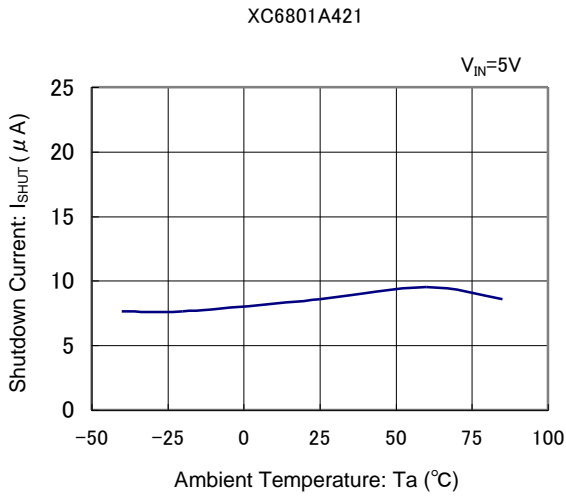

(16) Stand-by Current vs. Ambient Temperature

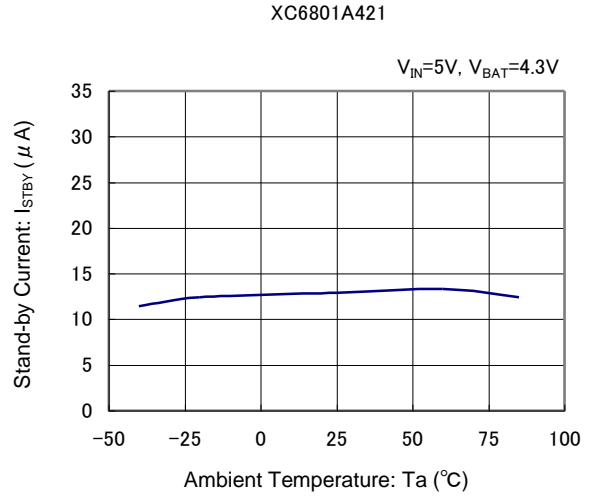

(17) /CHG Weak Pull Down Current vs. /CHG Pin Voltage

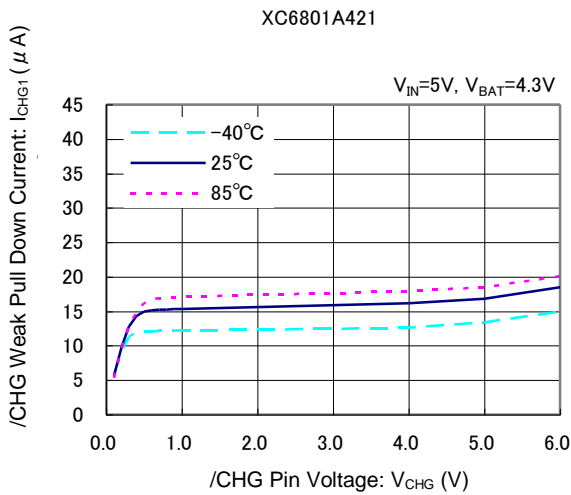

(18) /CHG Strong Pull Down Current vs. /CHG Pin Voltage

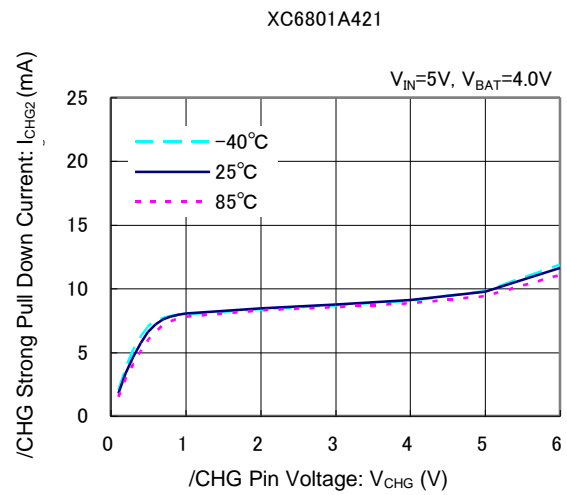

(19) /CHG Pin Output Low Voltage vs. Ambient Temperature

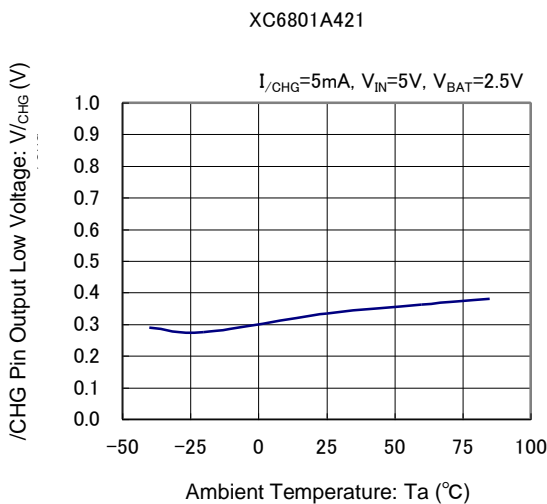

PACKAGING INFORMATION

SOT-25

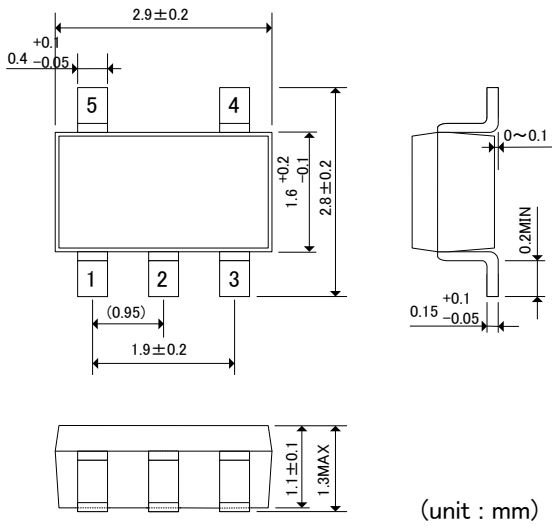

SOT-25 Reference Pattern Layout

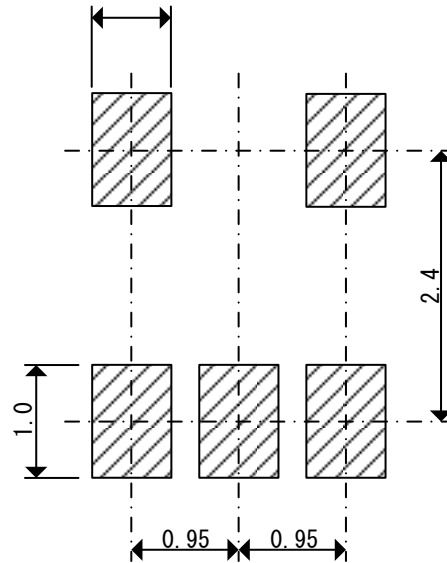

SOT-89-5

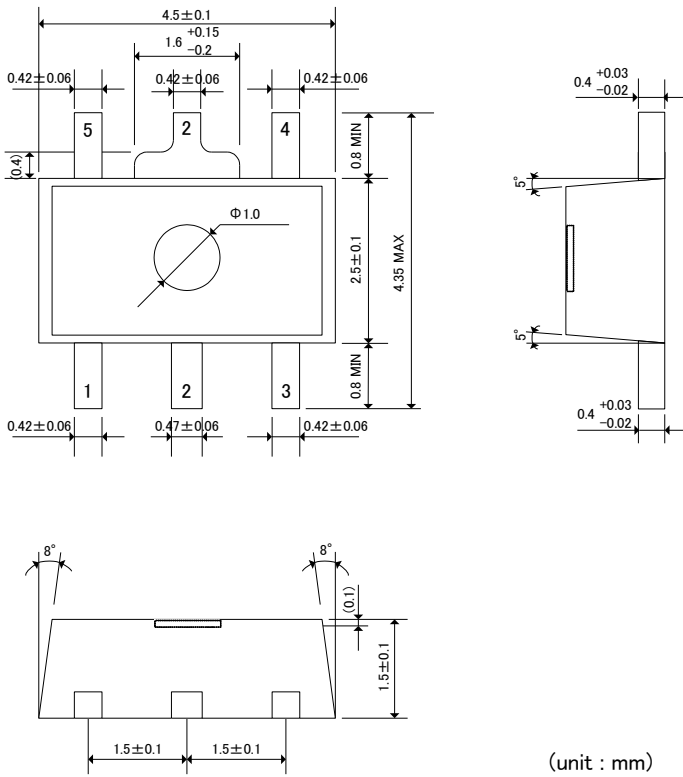

SOT-89-5 Reference Pattern Layout

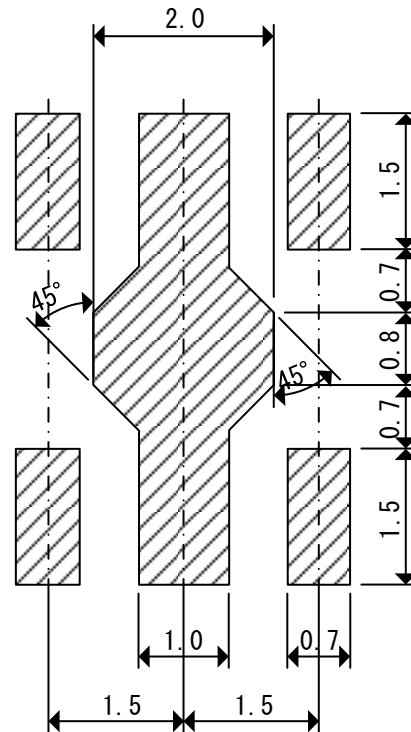

PACKAGING INFORMATION (Continued)

● USP-6C

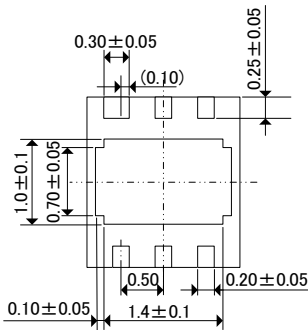
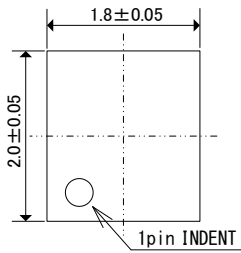

(unit : mm)

● USP-6C Reference Pattern Layout

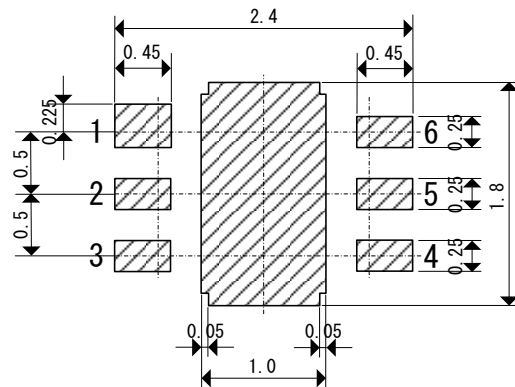

● USP-6C Reference Metal Mask Design

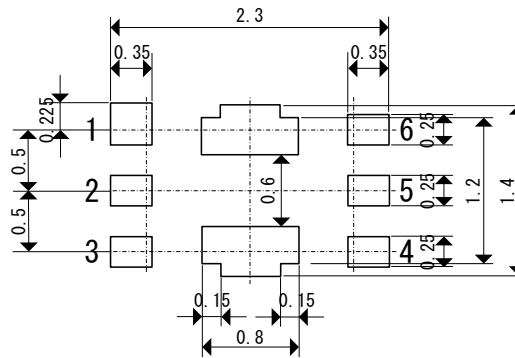

PACKAGING INFORMATION (Continued)

SOT-89-5 Power Dissipation

Power dissipation data for the SOT-89-5 is shown in this page.
The value of power dissipation varies with the mount board conditions.
Please use this data as the reference data taken in the following condition.

1. Measurement Condition

- Condition: Mount on a board
- Ambient: Natural convection
- Soldering: Lead (Pb) free
- Board: Dimensions 40 x 40 mm
(1600 mm² in one side)
- Copper (Cu) traces occupy 50% of the board area in top and back faces
- Package heat-sink is tied to the copper traces
- Material: Glass Epoxy (FR-4)
- Thickness: 1.6mm
- Through-hole: 5 x 0.8 Diameter

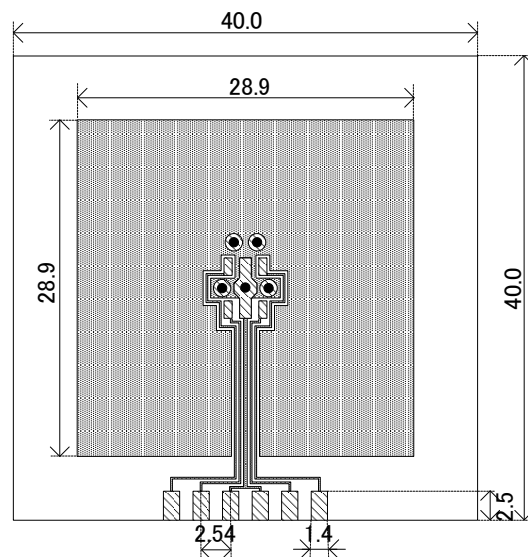

Evaluation Boardレイアウト(単位: mm)

2. Power Dissipation vs. Ambient Temperature

Board Mount (T_j max = 125°C)

Ambient Temperature (°C)	Power Dissipation Pd (mW)	Thermal Resistance (°C/W)
25	1300	76.92
85	520	

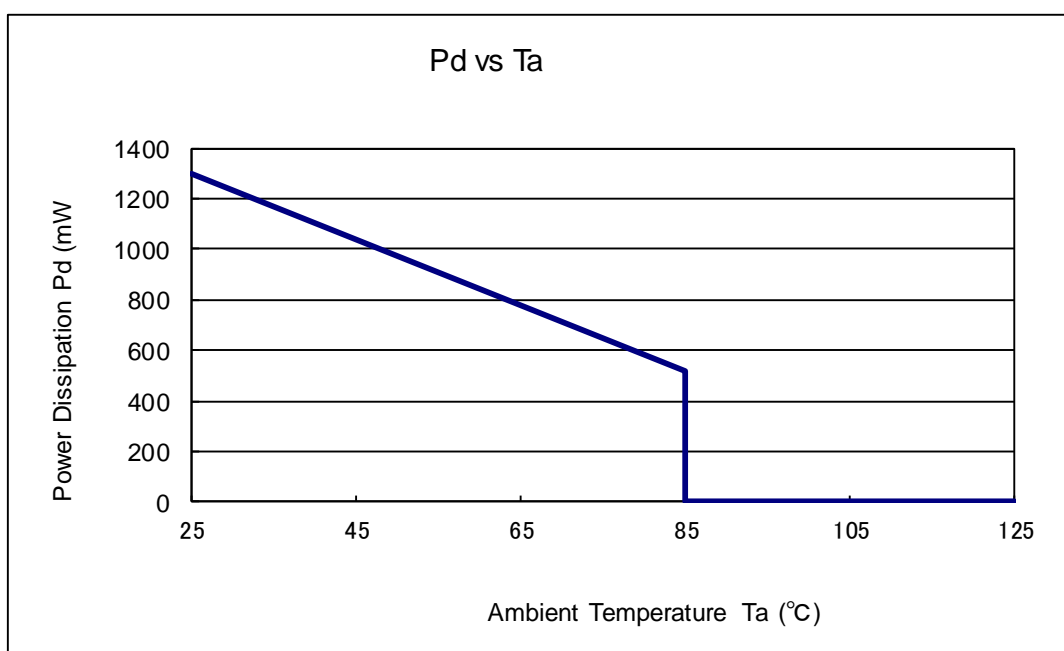

PACKAGING INFORMATION (Continued)

SOT-25 Power Dissipation

Power dissipation data for the SOT-25 is shown in this page.
 The value of power dissipation varies with the mount board conditions.
 Please use this data as the reference data taken in the following condition.

1. Measurement Condition

- Condition: Mount on a board
- Ambient: Natural convection
- Soldering: Lead (Pb) free
- Board: Dimensions 40 x 40 mm
 (1600 mm² in one side)
- Copper (Cu) traces occupy 50% of the board area in top and back faces
- Package heat-sink is tied to the copper traces
 (Board of SOT-26 is used.)
- Material: Glass Epoxy (FR-4)
- Thickness: 1.6mm
- Through-hole: 4 x 0.8 Diameter

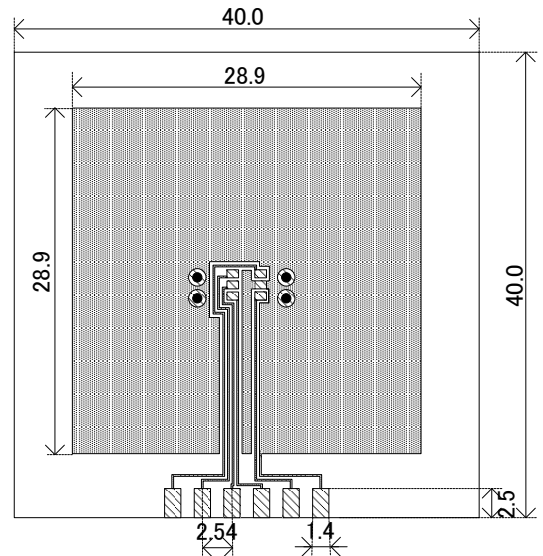

Evaluation Board (Unit: mm)

2. Power Dissipation vs. Ambient Temperature

Board Mount (T_J max = 125°C)

Ambient Temperature (°C)	Power Dissipation Pd (mW)	Thermal Resistance (°C/W)
25	600	166.67
85	240	

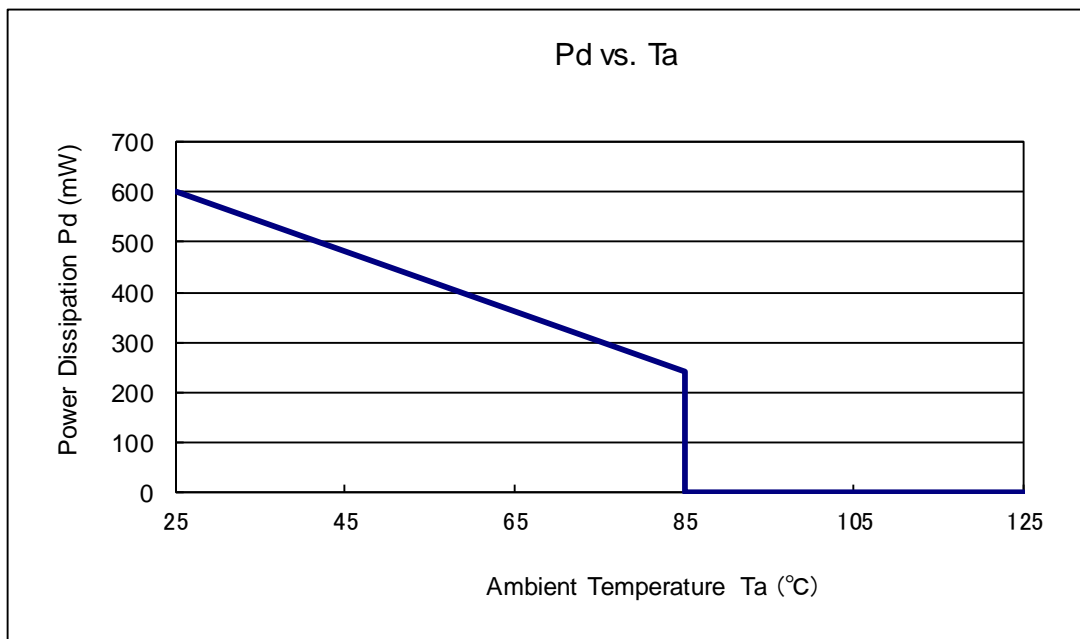

PACKAGING INFORMATION (Continued)

● USP-6C Power Dissipation

Power dissipation data for the USP-6C is shown in this page.

The value of power dissipation varies with the mount board conditions.

Please use this data as the reference data taken in the following condition.

1. Measurement Condition

- Condition : Mount on a board
- Ambient : Natural convection
- Soldering : Lead (Pb) free
- Board : Dimensions 40 x 40 mm
(1600 mm² in one side)
- Copper (Cu) traces occupy 50% of the board area in top and back faces
- Package heat-sink is tied to the copper traces
- Material : Glass Epoxy (FR-4)
- Thickness : 1.6mm
- Through-hole : 4 x 0.8 Diameter

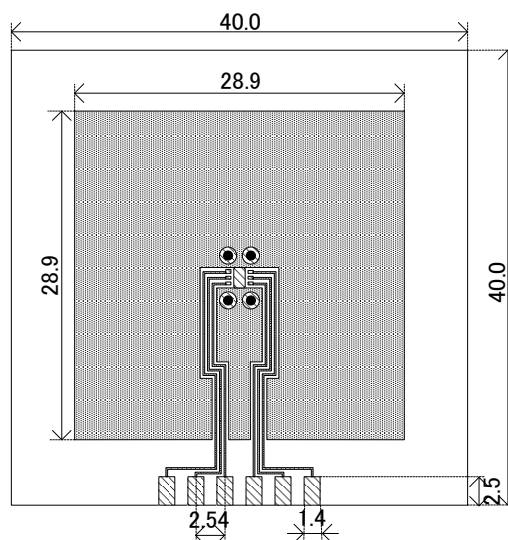

Evaluation Board (Unit : mm)

2. Power Dissipation vs. Ambient Temperature

Board Mount (T_j max = 125°C)

Ambient Temperature (°C)	Power Dissipation Pd (mW)	Thermal Resistance (°C/W)
25	1000	100.00
85	400	

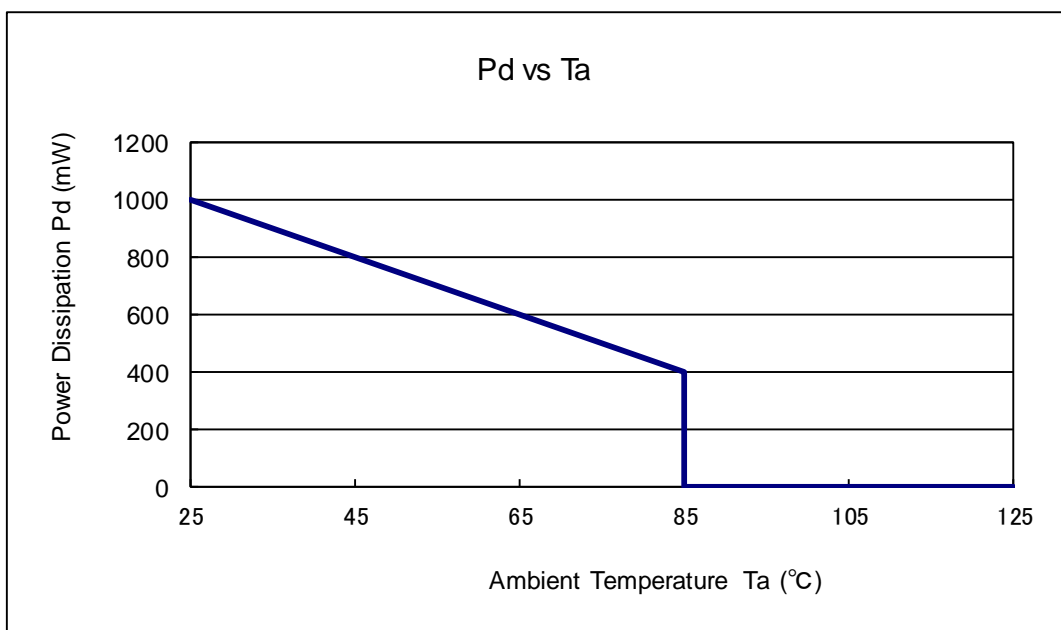

MARKING RULE

SOT-25

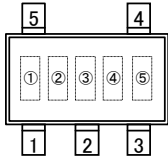

① represents product series

MARK	PRODUCT SERIES
4	XC6801*****-G

② represents the 7th digits

MARK	PRODUCT SERIES
A	XC6801A****-G

SOT-89-5

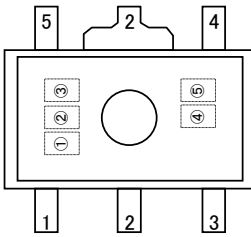

③ represents the 8th digits

MARK	PRODUCT SERIES
4	XC6801*4****-G

④⑤ represents production lot number

01~09, 0A~0Z, 11~9Z, A1~A9, AA ~Z9, ZA~ZZ in order.

(G, I, J, O, Q, W excepted)

*No character inversion used.

USP-6C

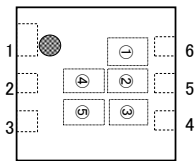

1. The product and product specifications contained herein are subject to change without notice to improve performance characteristics. Consult us, or our representatives before use, to confirm that the information in this datasheet is up to date.
2. The information in this datasheet is intended to illustrate the operation and characteristics of our products. We neither make warranties or representations with respect to the accuracy or completeness of the information contained in this datasheet nor grant any license to any intellectual property rights of ours or any third party concerning with the information in this datasheet.
3. Applicable export control laws and regulations should be complied and the procedures required by such laws and regulations should also be followed, when the product or any information contained in this datasheet is exported.
4. The product is neither intended nor warranted for use in equipment of systems which require extremely high levels of quality and/or reliability and/or a malfunction or failure which may cause loss of human life, bodily injury, serious property damage including but not limited to devices or equipment used in 1) nuclear facilities, 2) aerospace industry, 3) medical facilities, 4) automobile industry and other transportation industry and 5) safety devices and safety equipment to control combustions and explosions. Do not use the product for the above use unless agreed by us in writing in advance.
5. Although we make continuous efforts to improve the quality and reliability of our products; nevertheless Semiconductors are likely to fail with a certain probability. So in order to prevent personal injury and/or property damage resulting from such failure, customers are required to incorporate adequate safety measures in their designs, such as system fail safes, redundancy and fire prevention features.
6. Our products are not designed to be Radiation-resistant.
7. Please use the product listed in this datasheet within the specified ranges.
8. We assume no responsibility for damage or loss due to abnormal use.
9. All rights reserved. No part of this datasheet may be copied or reproduced unless agreed by Torex Semiconductor Ltd in writing in advance.

TOREX SEMICONDUCTOR LTD.