

XC3101 Series

Ultra Small Analog Output Temperature Sensor with Alarm Output Pin

■ GENERAL DESCRIPTION

The XC3101 series is a temperature sensor IC which features ultra small, low current consumption, and high-accurate detection.

It can provide both analog and alarm outputs. The alarm output configures N-channel open-drain. The device consists of a band-gap type temperature sensor, a voltage reference, a temperature setting tilt amplifier, a comparator, and various set resistors.

Alarm temperature is internally set at 70°C.

When the temperature exceeds a set point, the alarm output is maintained as "Low".

When the temperature drops a pre-set hysteresis width from the set point, the alarm output is released to "High". The hysteresis width is 5°C.

An analog voltage output is provided in a high-accuracy which is guaranteed in the operating temperature range of -40°C to 100°C. An external A/D can monitor the sensing temperature.

The operating input voltage range is 2.7 to 5.5V. The small consumption current of 3.5µA (TYP.) is ideally suited for temperature detection for battery devices. The ultra small USPN-4 (1.2 x 0.9 x 0.4) package is available for the high-density board mounting in mobile device applications as well as an industry standard package SSOT-24.

■ APPLICATIONS

- Base temperature monitoring on mobile devices
- Internal temperature monitoring on small electronic device
- Temperature monitoring (LCD, Module)
- Temperature control for FAN

■ FEATURES

Operating Voltage Range	: 2.7V~5.5V
Analog Output Voltage	: 1.600V (TYP.) @25°C 2.365V (TYP.) @-40°C 0.717V (TYP.) @100°C
Analog Output Temp. Coefficient	: -11.77mV/°C(TYP.)
Analog Output Temp. Range	: -40°C~+100°C
Analog Temperature Accuracy	: ±3.5°C
Alarm Temperature	: 70°C±4.5°C
Alarm Hysteresis	: 5°C (TYP.)
Alarm Output Configuration	: N-channel Open-Drain
Alarm Output Logic	: Active Low Alarm
Low Power Consumption	: 3.5µA (TYP.) @25°C
Packages	: USPN-4, SSOT-24
Environmentally Friendly	: EU RoHS Compliant, Pb Free

■ TYPICAL APPLICATION CIRCUIT

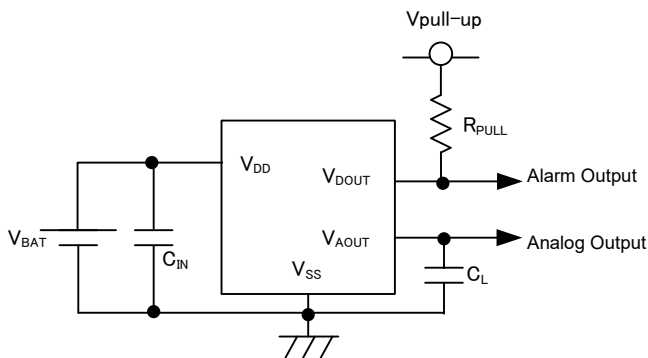

■ TYPICAL PERFORMANCE CHARACTERISTICS

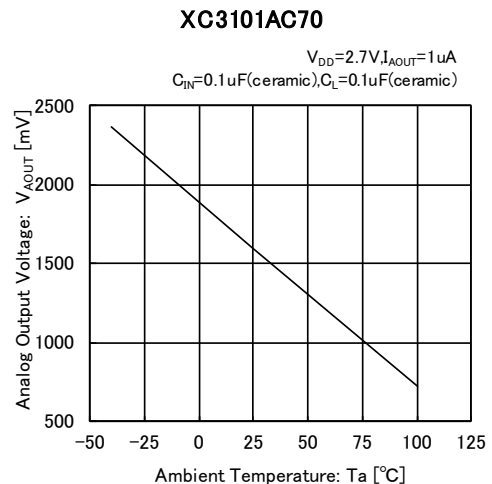

PIN CONFIGURATION

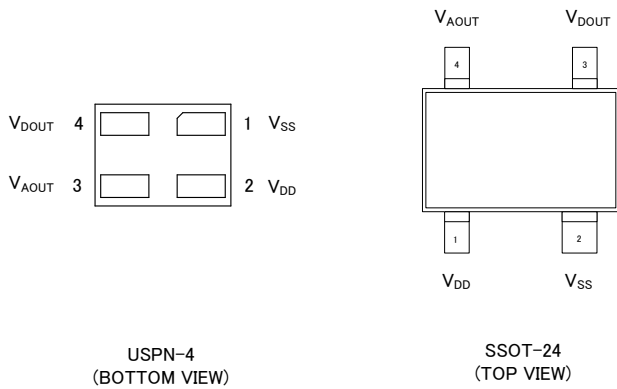

PIN ASSIGNMENT

PIN NUMBER		PIN NAME	FUNCTIONS
USPN-4	SSOT-24		
2	1	V _{DD}	Power Supply Input
1	2	V _{SS}	Ground
4	3	V _{DOUT}	Alarm Output
3	4	V _{AOUT}	Analog Output

PRODUCT CLASSIFICATION

Ordering Information

PRODUCT NAME	ALARM TEMPERATURE (*2)	HYSTERESIS WIDTH (*3)	PACKAGE	ORDER UNIT
XC3101AC70NR-G(*1)	70°C	5°C	SSOT-24	3,000pcs/Reel
XC3101AC707R-G(*1)	70°C	5°C	USPN-4	5,000pcs/Reel

(*1) The "-G" suffix denotes Halogen and Antimony free as well as being fully EU RoHS compliant.

(*2) For other alarm temperature besides 70°C, please ask Torex sales contacts.

Optional setting range is 50°C~95°C.

(*3) The hysteresis width selections are available in 5°C and 2 other optional for alarm temperature.

PRODUCT NAME	HYSTERESIS WIDTH	DESCRIPTION
XC3101AA	0°C (TYP.)	Semi-custom
XC3101AB	2.4°C (TYP.)	Semi-custom
XC3101AC	5°C (TYP.)	Standard

■ BLOCK DIAGRAM

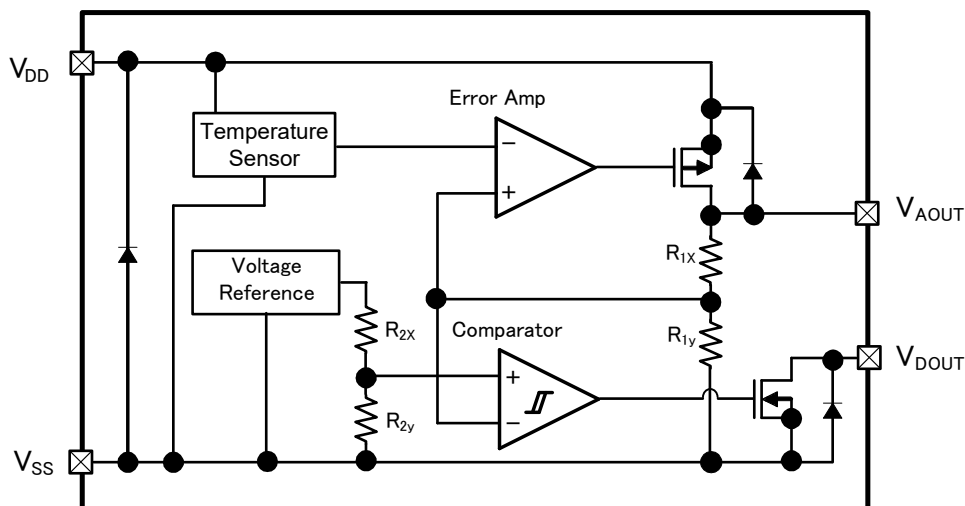

*Diodes inside the circuit are an ESD protection diode and a parasitic diode.

■ ABSOLUTE MAXIMUM RATINGS

Ta=25°C

PARAMETER	SYMBOL	RATINGS	UNITS
Input Voltage	V _{DD}	V _{SS} -0.3~+7.0	V
Analog Output Voltage	V _{AOUT}	V _{SS} -0.3~V _{DD} +0.3	V
Alarm Output Voltage	V _{DOUT}	V _{SS} ~V _{SS} +7.0	V
Output Current	I _{DOUT} , I _{AOUT}	30	mA
Power Dissipation	USPN-4	Pd	100
	SSOT-24		150
Operating Ambient Temperature	Ta	-40~+100	°C
Storage Temperature	Tstg	-55~+125	°C

ELECTRICAL CHARACTERISTICS

XC3101AC70

PARAMETER	SYMBOL	CONDITIONS	MIN.	TYP.	MAX.	UNITS	CIRCUIT
Power Input Range	V_{DD}	$-40^{\circ}\text{C} \leq T_a \leq 100^{\circ}\text{C}$	2.7	-	5.5	V	-
Supply Current	I_{DD}	$V_{DD}=3.6\text{V}$, No load	-	3.5	6	μA	②
Analog Output Voltage	V_{AOUT}	$T_a=-40^{\circ}\text{C}$, $V_{DD}=2.7\text{V} \sim 5.5\text{V}$, $I_{AOUT}=10\mu\text{A}$	2324	2365	2406	mV	①
		$T_a=25^{\circ}\text{C}$, $V_{DD}=2.7\text{V} \sim 5.5\text{V}$, $I_{AOUT}=10\mu\text{A}$	1559	1600	1641	mV	①
		$T_a=100^{\circ}\text{C}$, $V_{DD}=2.7\text{V} \sim 5.5\text{V}$, $I_{AOUT}=10\mu\text{A}$	676	717	758	mV	①
Analog Output Voltage Temperature Coefficient	$d V_{AOUT} / dT$	$V_{DD}=2.7\text{V} \sim 5.5\text{V}$, $I_{AOUT}=10\mu\text{A}$	-12.52	-11.77	-11.08	mV/ $^{\circ}\text{C}$	① ①
Linearity Margin Error		$V_{DD}=2.7\text{V} \sim 5.5\text{V}$, $I_{AOUT}=10\mu\text{A}$	-	± 0.4	-	%	①
Load Regulation	$\Delta V_O / \Delta I_O$	$1\mu\text{A} \leq I_{AOUT} \leq 1\text{mA}$	-	5	10	mV	①
Analog Output Current	I_{AOUT}	$V_{DD}=2.7\text{V} \sim 5.5\text{V}$	1	-	-	mA	①
Alarm Temperature	T_{DET}	$V_{DD}=2.7\text{V} \sim 5.5\text{V}$, $I_{AOUT}=10\mu\text{A}$ Change from low temperature to high temperature	65.5	70.0	74.5	$^{\circ}\text{C}$	①
Alarm Temperature Hysteresis Width	T_{HYS}	$V_{DD}=2.7\text{V} \sim 5.5\text{V}$, $I_{AOUT}=10\mu\text{A}$	$T_{DET} - 6.5$	$T_{DET} - 5$	$T_{DET} - 3.5$	$^{\circ}\text{C}$	①
Alarm Output Current	I_{DOUT}	$V_{DD}=2.7\text{V}$, $V_{DOUT}=0.3\text{V}$, $V_{AOUT}=V_{SS}$ N-ch open drain output	1	-	-	mA	③
Alarm Output Leakage Current	$I_{DOUTLEAK}$	$V_{DD}=5.5\text{V}$, $V_{DOUT}=5.5\text{V}$, $V_{AOUT}=2.5\text{V}$	-	0.001	0.2	μA	③

NOTE:

(*1) The value is specified in design values under shipping inspection at a normal temperature and a high temperature.

TEST CIRCUITS

Circuit ①

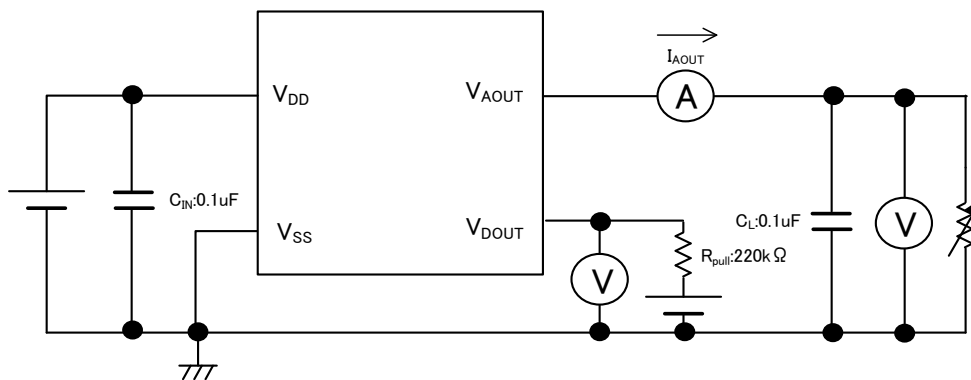

Circuit ②

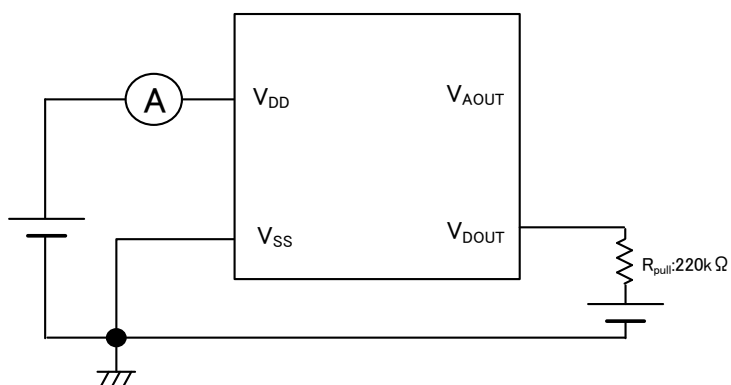

Circuit ③

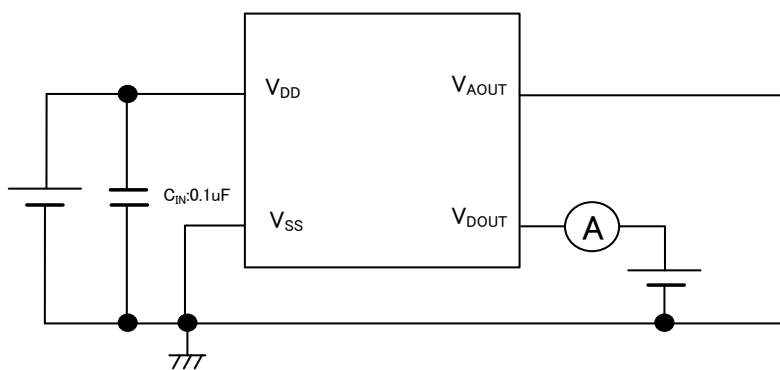

Circuit ④

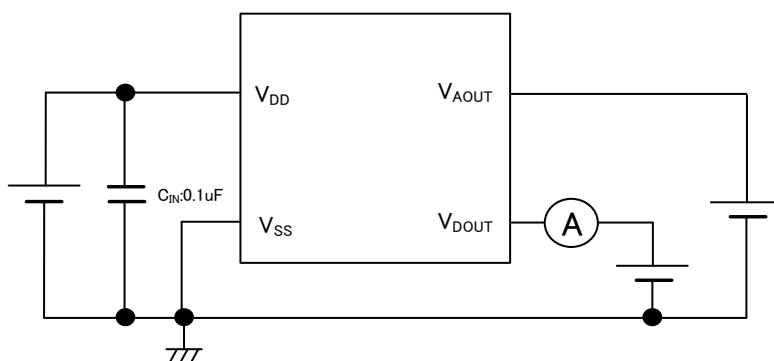

OPERATIONAL EXPLANATION

A small ratio of the analog output (V_{AOUT}) of the XC3101 series is fed back to one input of the error amplifier via the voltage divider formed by the R_{1x} and R_{1y} resistances. The error amplifier compares this feedback voltage with the voltage of the internal temperature sensor that is connected to its other input, and the resulting output signal from the error amplifier drives the Pch-MOS transistor that is connected between the V_{DD} and V_{AOUT} pins. This cycle of events stabilizes the V_{AOUT} voltage via negative feedback. The internal temperature sensor is controlled so that the voltage changes on a fixed temperature slope with respect to changes of ambient temperature, and a voltage with a fixed temperature slope is thereby output from the analog output (V_{AOUT}).

By comparing the internal voltage reference –which has a small temperature slope- with the voltage, divided by R_{1x} and R_{1y} , of the analog output (V_{AOUT}) –which has a fixed temperature slope-, the comparator outputs a voltage that turns the Nch-MOS transistor ON and OFF. Since this Nch-MOS transistor is connected to the V_{DOUT} pin, we actually control the alarm output voltage (V_{DOUT}).

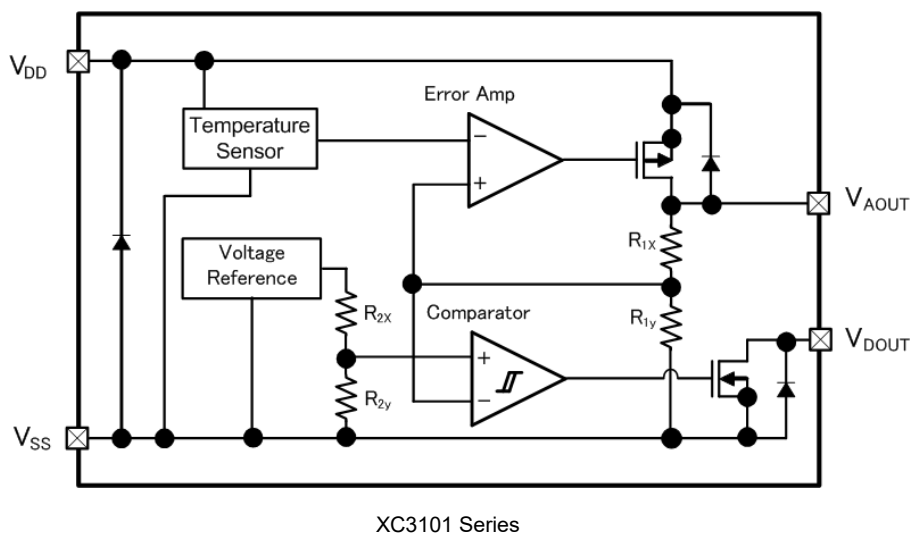

<Analog output>

Due to its fixed temperature slope over the temperature range of -40°C to 100°C , the analog output (V_{AOUT}) of the XC3101 series outputs a voltage that varies linearly with changes in ambient temperature. For the XC3101A type, whose temperature slope is $-11.77\text{mV}/^{\circ}\text{C}$ (typical), the analog output voltage at $T_a=25^{\circ}\text{C}$ is 1.6V (typical). The temperature accuracy by means of the analog output voltage is $\pm 3.5^{\circ}\text{C}$.

<Alarm output>

The alarm output (V_{DOUT}) of the XC3101 series holds the alarm output voltage at Low (V_{SS} potential) when the ambient temperature rises and the alarm temperature –a threshold set inside the IC- is exceeded. When the ambient temperature drops below the alarm temperature by an amount that is bigger than the hysteresis width, the alarm output voltage goes High (pull-up voltage). The alarm output pin is an Nch open drain output, and thus when using alarm output, connect a pull-up resistor to pull the voltage up to the desired voltage. If not using alarm output, pull the alarm output pin down to the V_{SS} potential.

<Input/output capacitor>

To stabilize the operation of the XC3101 series, connect a $0.1\mu\text{F}$ or higher output capacitor (C_L) between the V_{AOUT} and V_{SS} pins. To stabilize the input power supply, connect a $0.1\mu\text{F}$ or higher input capacitor (C_{IN}).

■ NOTES ON USE

1. Please use this IC within the stated maximum ratings. For temporary, transitional voltage drop or voltage rising phenomenon, the IC is liable to malfunction should the ratings be exceeded.
2. When the wiring impedance is high, noise wraparound due to the output current may cause analog output or alarm output operation to become unstable. Sufficiently strengthen the V_{DD} and GND wiring.
3. The input capacitor C_{IN} and the output capacitor C_L should be placed to the as close as possible with a shorter wiring.
4. Do not use the XC3101 series with a voltage lower than V_{SS} applied to the alarm output pin (V_{DOUT}).
5. If V_{IN} changes sharply, the analog output will also change sharply, and malfunctioning of the alarm output may result. In this event, adjust the slew-rate to less than 2 V/ms by increasing the input capacitor (C_{IN}) or other means.
6. Torex places an importance on improving our products and its reliability.
However, by any possibility, we would request user fail-safe design and post-aging treatment on system or equipment.

TYPICAL PERFORMANCE CHARACTERISTICS

(1) Supply Current vs. Ambient Temperature

XC3101AC70

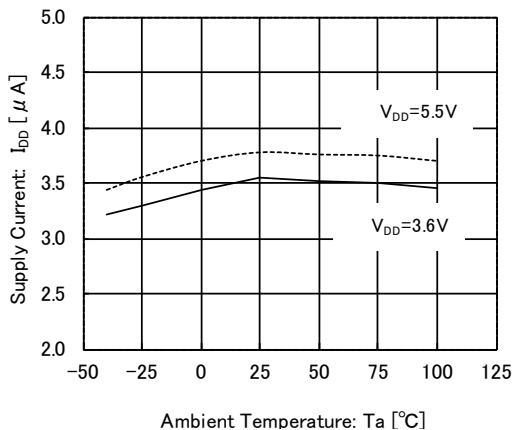

(2) Analog Output Voltage vs. Ambient Temperature

XC3101AC70

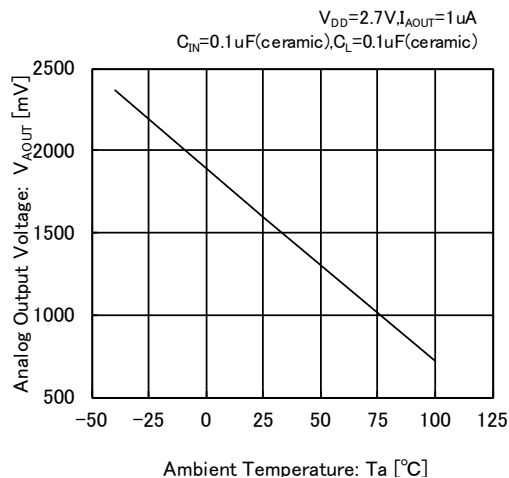

(3) Analog Output Temperature Error vs. Ambient Temperature

XC3101AC70

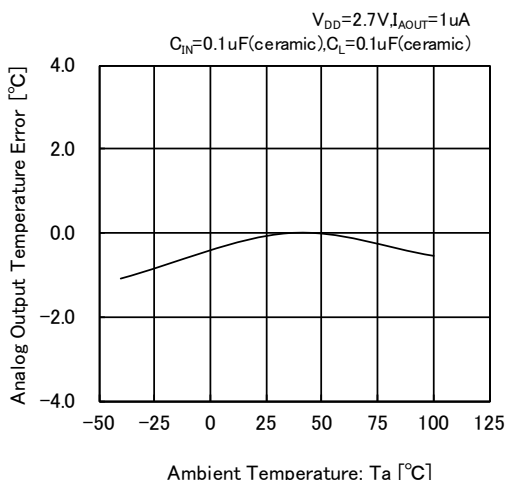

(4) Linearity Margin Error vs. Ambient Temperature

XC3101AC70

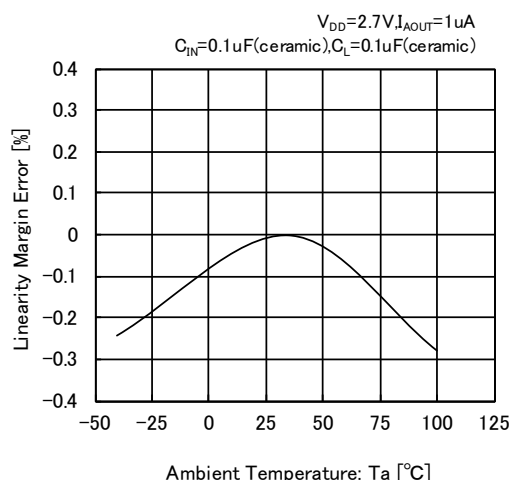

(5) Alarm Output Voltage vs. Ambient Temperature

XC3101AC70

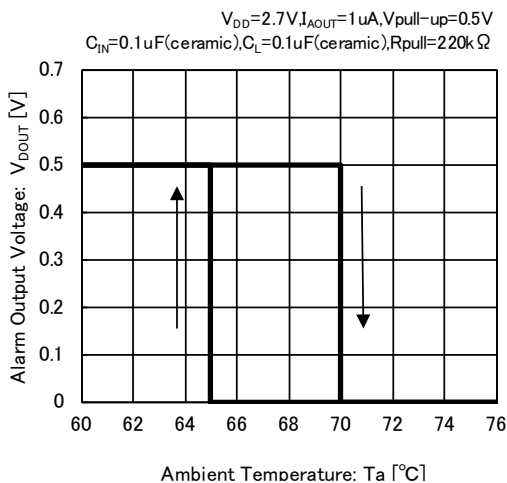

■ TYPICAL PERFORMANCE CHARACTERISTICS (Continued)

(6) Analog Output Voltage vs. Analog Output Current

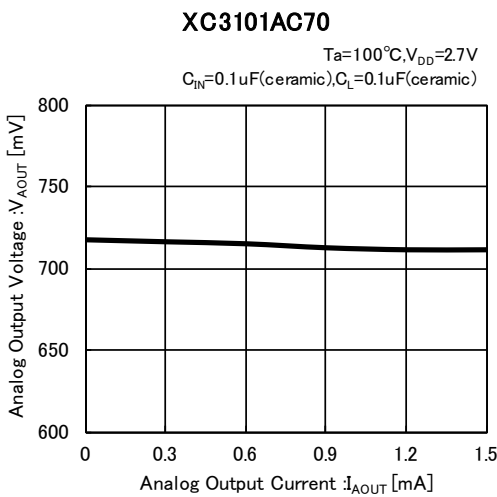
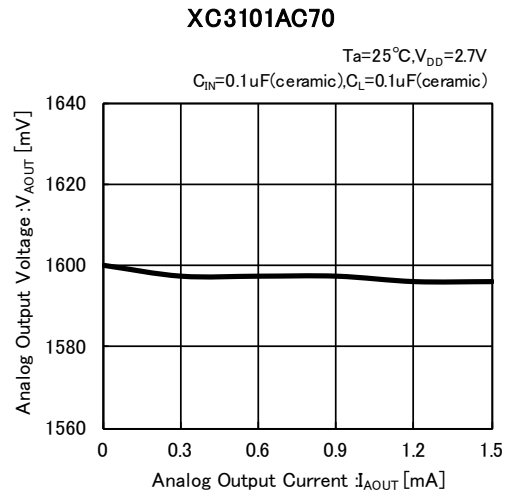
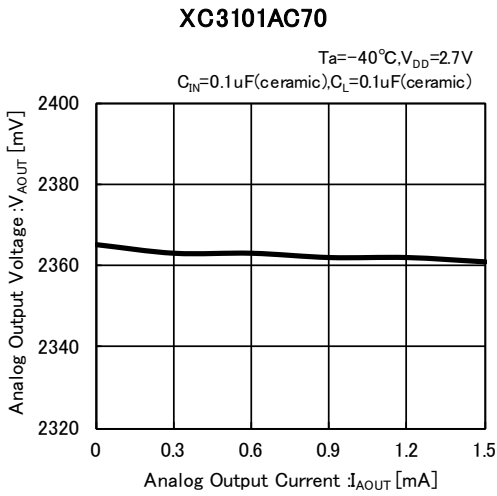

(7) Alarm Output Current vs. Ambient Temperature

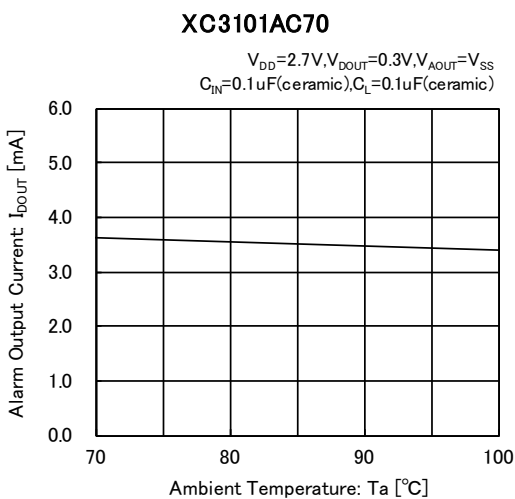

(8) Alarm Output Current vs. Input Voltage

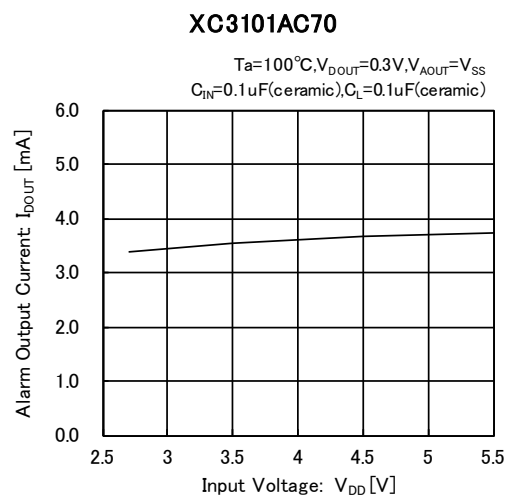

PACKAGING INFORMATION

●SSOT-24

Unit: mm

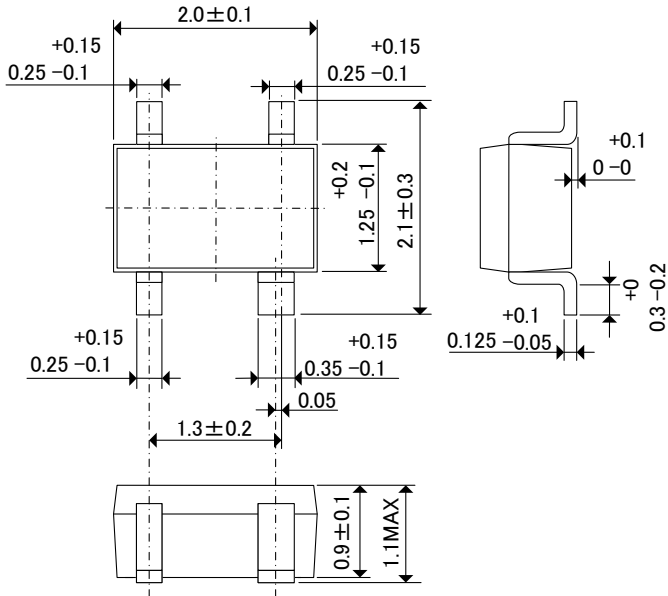

●USPN-4

Unit: mm

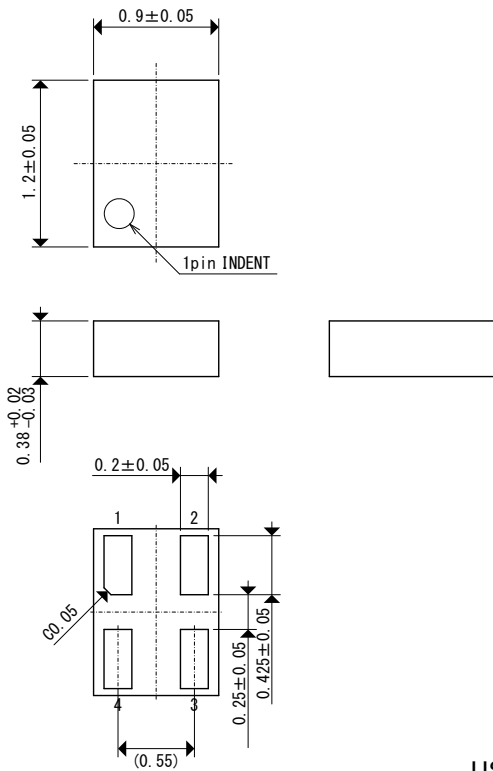

USPN-4 Package

■ **PACKAGING INFORMATION (Continued)**

●USPN-4 Reference Pattern Layout

Unit: mm

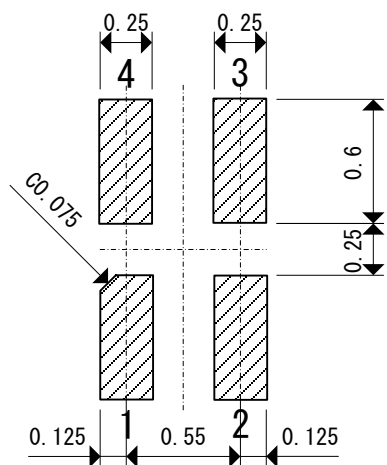

●USPN-4 Reference Metal Mask Design

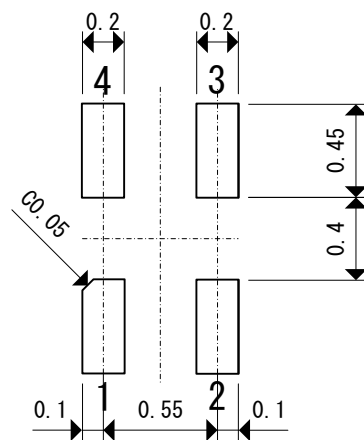

MARKING RULE

●SSOT-24

(With the orientation bar at the bottom)

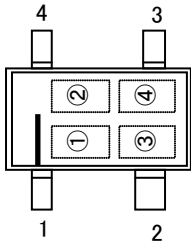

① represents product series

MARK	PRODUCT SERIES
N	XC3101*****-G

* SSOT-24 has the orientation bar marked in the bottom.

② represents production registered number

0~0, A~Z are in an order.

(G, I, J, O, Q, W excluded.)

* No character inversion used.

③④ represents production lot number.

01~09, 0A~0Z, 11~9Z, A1~A9, AA~AZ, B1~ZZ repeated.

(G, I, J, O, Q, W excluded.)

* No character inversion used.

●USPN-4

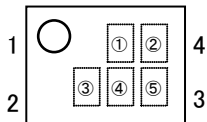

① represents product series

MARK	PRODUCT SERIES
D	XC3101*****-G

②③ represents production registered number

01~09, 0A~0Z, 11~9Z, A1~A9, AA~AZ, B1~ZZ are in an order.

(G, I, J, O, Q, W excluded.)

* No character inversion used.

④⑤ represents production lot number.

01~09, 0A~0Z, 11~9Z, A1~A9, AA~AZ, B1~ZZ repeated.

(G, I, J, O, Q, W excluded.)

* No character inversion used.

1. The product and product specifications contained herein are subject to change without notice to improve performance characteristics. Consult us, or our representatives before use, to confirm that the information in this datasheet is up to date.
2. The information in this datasheet is intended to illustrate the operation and characteristics of our products. We neither make warranties or representations with respect to the accuracy or completeness of the information contained in this datasheet nor grant any license to any intellectual property rights of ours or any third party concerning with the information in this datasheet.
3. Applicable export control laws and regulations should be complied and the procedures required by such laws and regulations should also be followed, when the product or any information contained in this datasheet is exported.
4. The product is neither intended nor warranted for use in equipment of systems which require extremely high levels of quality and/or reliability and/or a malfunction or failure which may cause loss of human life, bodily injury, serious property damage including but not limited to devices or equipment used in 1) nuclear facilities, 2) aerospace industry, 3) medical facilities, 4) automobile industry and other transportation industry and 5) safety devices and safety equipment to control combustions and explosions. Do not use the product for the above use unless agreed by us in writing in advance.
5. Although we make continuous efforts to improve the quality and reliability of our products; nevertheless Semiconductors are likely to fail with a certain probability. So in order to prevent personal injury and/or property damage resulting from such failure, customers are required to incorporate adequate safety measures in their designs, such as system fail safes, redundancy and fire prevention features.
6. Our products are not designed to be Radiation-resistant.
7. Please use the product listed in this datasheet within the specified ranges.
8. We assume no responsibility for damage or loss due to abnormal use.
9. All rights reserved. No part of this datasheet may be copied or reproduced unless agreed by Torex Semiconductor Ltd in writing in advance.

TOREX SEMICONDUCTOR LTD.