

XBP1002

ETR29004-002

Low Capacitance TVS Diode Array

FEATURES

- Terminal Capacitance** : 1.0pF (Line-to-GND)
- ESD Protection** : 8kV Contact (IEC61000-4-2)
- Environmentally Friendly** : EU RoHS Compliant, Pb Free

APPLICATIONS

- USB2.0, Firewire
- Video Graphics Card
- DVI
- Ethernet 10/100/1000

APPLICATION CIRCUIT

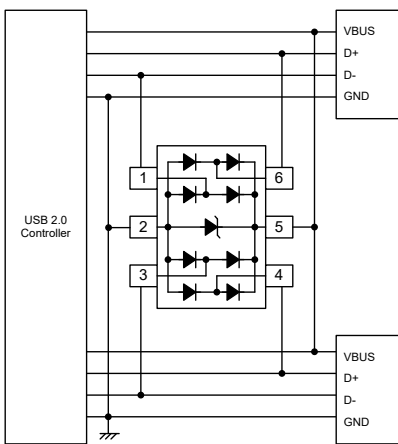

PACKAGING INFORMATION

● SOT-363 Unit: inch (mm)

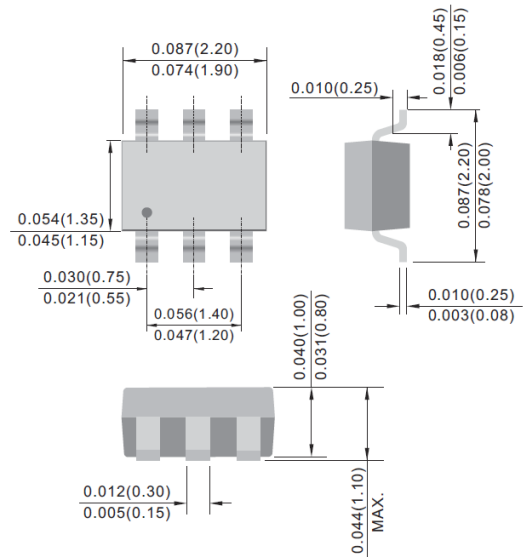

PRODUCT NAME

| PRODUCT NAME | PACKAGE | ORDER UNIT |
|--------------|---------|--------------|
| XBP1002-G * | SOT-363 | 3,000 / Reel |

* The "-G" suffix denotes Halogen and Antimony free as well as being fully RoHS compliant.

ABSOLUTE MAXIMUM RATINGS

Ta=25°C

| PARAMETER | SYMBOL | RATINGS | UNITS |
|---------------------------------------|--------|------------|-------|
| Peak Pulse Power (8/20 μs Waveform) | Ppk | 150 | W |
| Peak Pulse Current (8/20 μs Waveform) | Ipp | 6 | A |
| Junction Temperature | Tj | -55 to 150 | °C |
| Storage Temperature | Tstg | -55 to 150 | °C |

■ ELECTRICAL CHARACTERISTICS

Ta=25°C

| PARAMETER | SYMBOL | TEST CONDITIONS | LIMITS | | | UNITS |
|----------------------------------|-----------|--|--------|------|------|---------|
| | | | MIN. | TYP. | MAX. | |
| Stand-Off Voltage | V_{RWM} | | - | - | 5 | V |
| Breakdown Voltage | V_{BR} | $I_R=1mA$, Pin5 to 2 | 6 | - | - | V |
| Leakage Current | I_R | $V_R=5V$, Pin5 to 2 | - | 1 | 3 | μA |
| Clamping Voltage (8/20 μs) | V_C | $I_{PP}=1A$, I/O pin to Pin2 | - | - | 15 | V |
| Clamping Voltage (8/20 μs) | V_C | $I_{PP}=6A$, I/O pin to Pin2 | - | - | 25 | V |
| Terminal Capacitance | C_t | $V_R=0V$, $f=1MHz$ Between I/O lines and GND | - | - | 1 | pF |
| | | $V_R=0V$, $f=1MHz$ Between I/O lines | - | - | 0.5 | pF |

■ NOTES ON USE

1. Please use this IC within the absolute maximum ratings.

Even within the ratings, in case of high load use continuously such as high temperature, high voltage, high current and thermal stress may cause reliability degradation of the IC.

2. Torex places an importance on improving our products and their reliability.

We request that users incorporate fail-safe designs and post-aging protection treatment when using Torex products in their systems.

■ REFERENCE PATTERN LAYOUT

● SOT-363

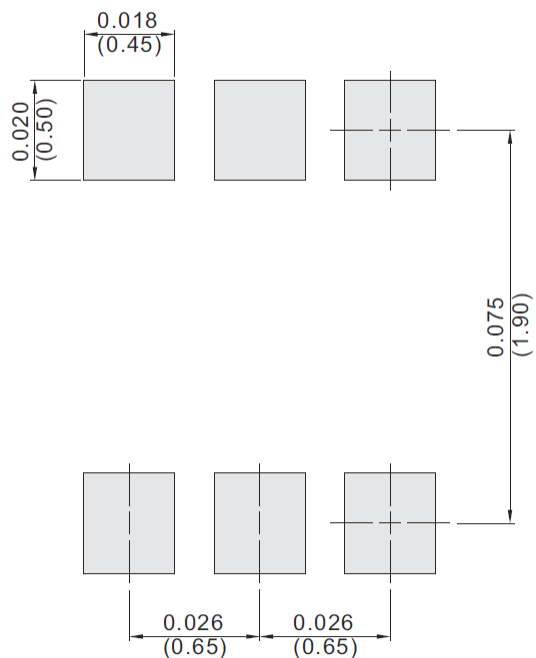

■ MARKING

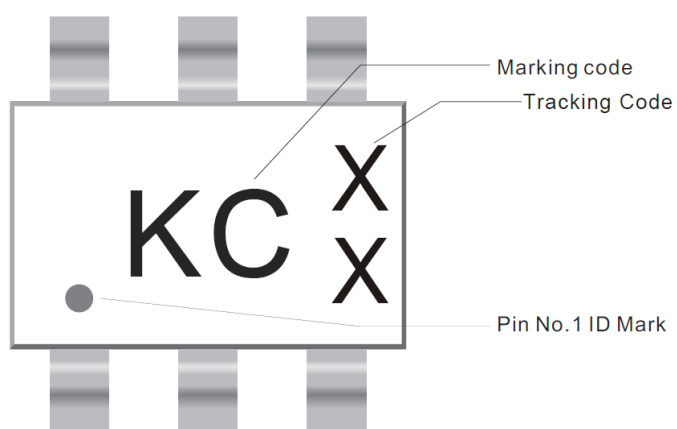

TAPING SPECIFICATIONS

●SOT-363

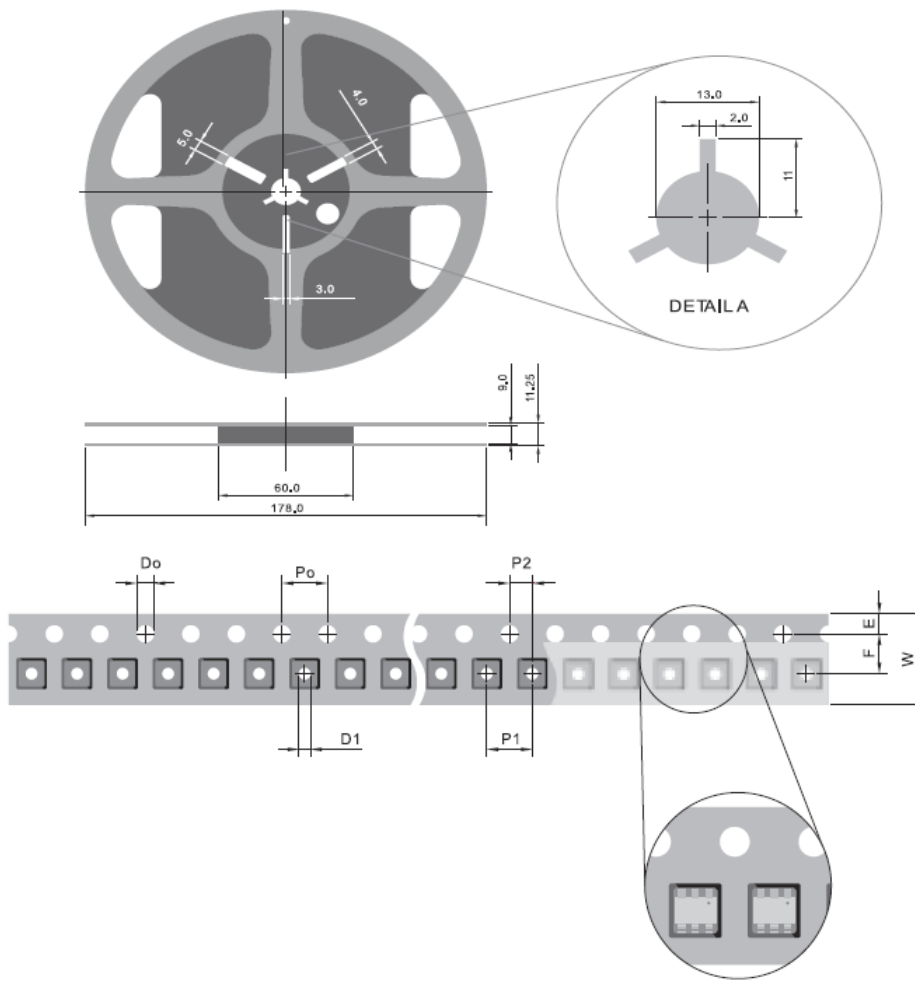

| SYMBOL | mm |
|--------|--------------------|
| D0 | 1.50 ± 0.10 |
| D1 | 1.00 ± 0.25 |
| E | 1.75 ± 0.10 |
| F | 3.50 ± 0.05 |
| P0 | 4.00 ± 0.10 |
| P1 | 4.00 ± 0.10 |
| P2 | 2.00 ± 0.05 |
| W | 8.00 + 0.3 -0.1 |

1. The products and product specifications contained herein are subject to change without notice to improve performance characteristics. Consult us, or our representatives before use, to confirm that the information in this datasheet is up to date.
2. We assume no responsibility for any infringement of patents, patent rights, or other rights arising from the use of any information and circuitry in this datasheet.
3. Please ensure suitable shipping controls (including fail-safe designs and aging protection) are in force for equipment employing products listed in this datasheet.
4. The products in this datasheet are not developed, designed, or approved for use with such equipment whose failure or malfunction can be reasonably expected to directly endanger the life of, or cause significant injury to, the user.
(e.g. Atomic energy; aerospace; transport; combustion and associated safety equipment thereof.)
5. Please use the products listed in this datasheet within the specified ranges.
Should you wish to use the products under conditions exceeding the specifications, please consult us or our representatives.
6. We assume no responsibility for damage or loss due to abnormal use.
7. All rights reserved. No part of this datasheet may be copied or reproduced without the prior permission of TOREX SEMICONDUCTOR LTD.

TOREX SEMICONDUCTOR LTD.